



Arquitetura e Urbanismo • UniEVANGÉLICA

# Habitação de interesse social

# Vila Container



Acadêmico: Kayo Gomes

Orientadora: Celina F. A. Manso

# A HABITAÇÃO



# À CIDADE DE ANÁPOLIS E O SUPPORTO À FERROVIA

## O processo de formação do comércio

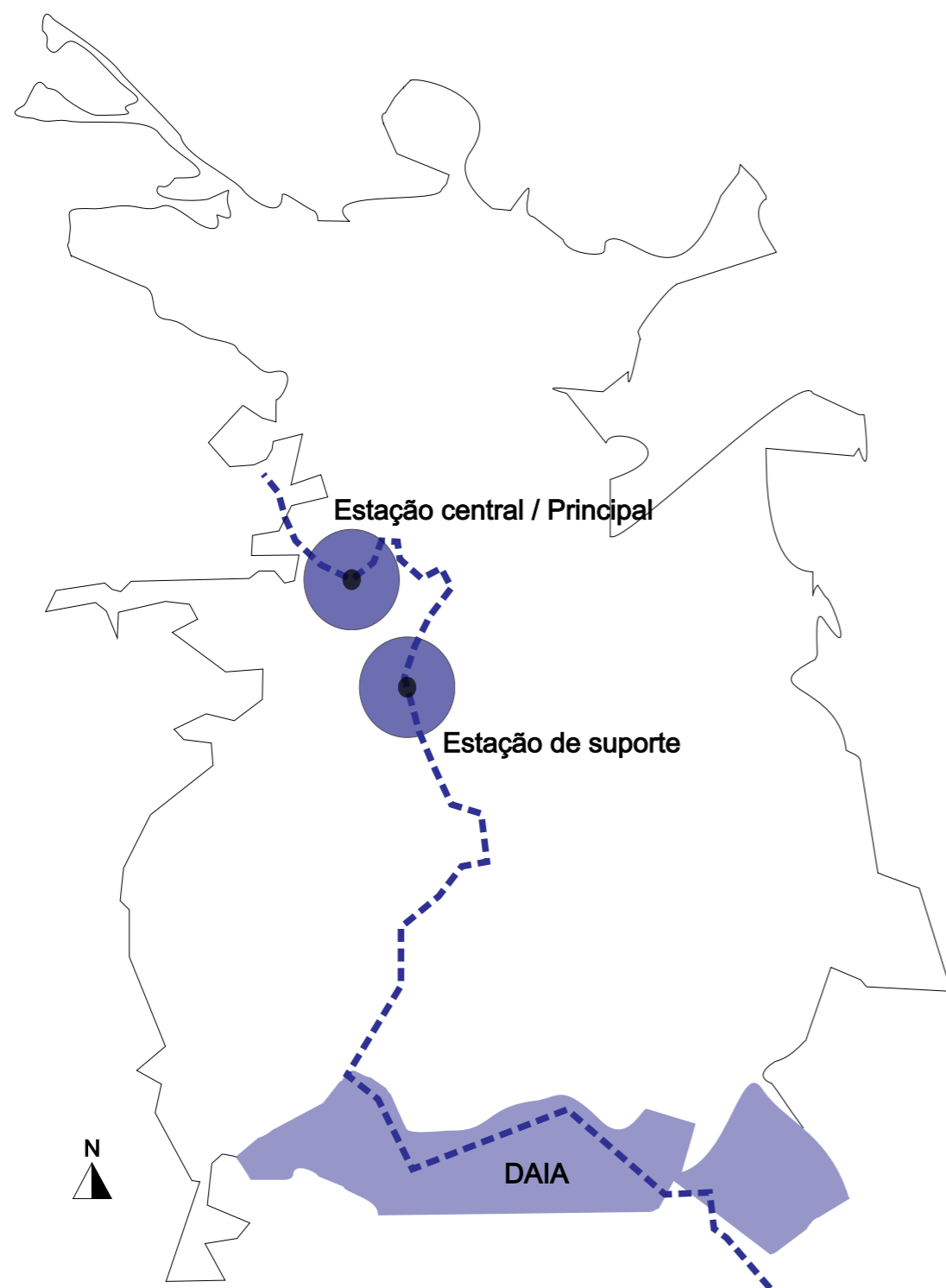

# Habitações sociais em Anápolis

Anápolis

An aerial photograph of Anápolis, Brazil, with a semi-transparent map overlay. The map shows the city's boundaries in a light blue color. Six small blue squares are placed on the map to indicate the locations of social housing projects. The squares are located at the northern, eastern, and southern peripheries of the city. The text 'Anápolis' is written in black over the map area.

# Localização

Bairro Jundiá industrial

Extensão da área de exercício projetual.

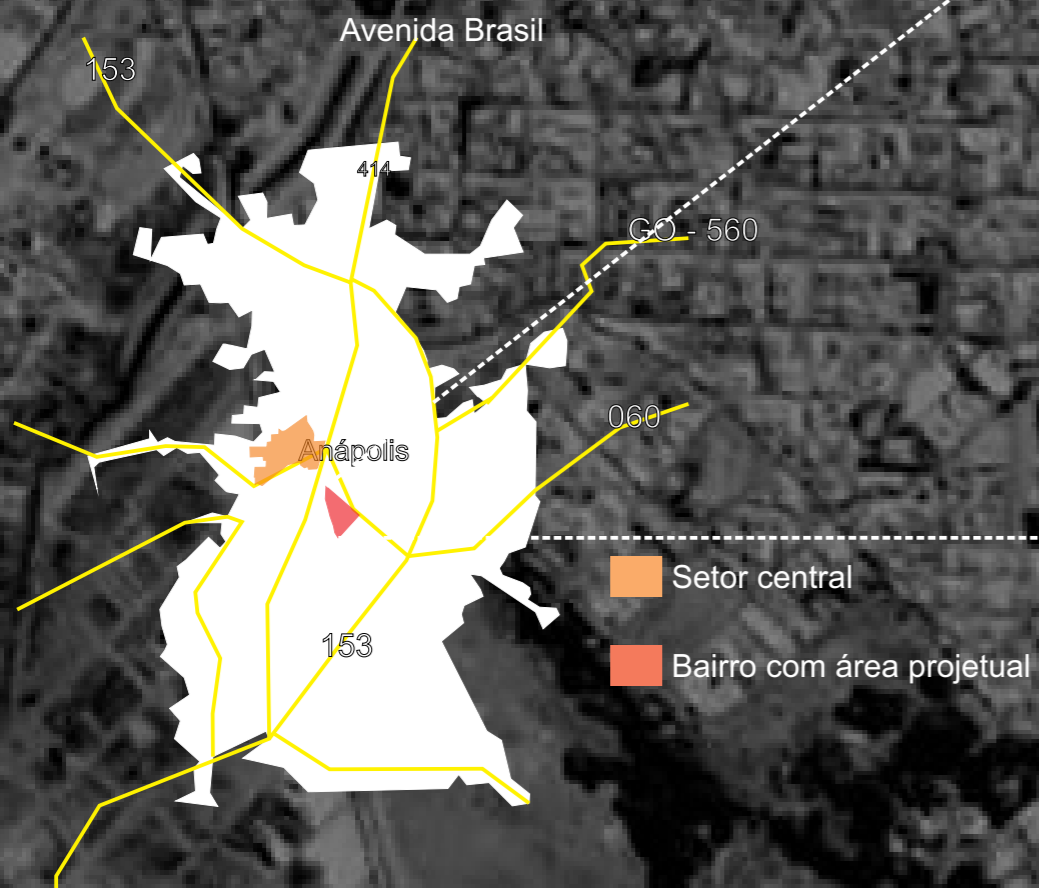

- Setor central
- Bairro com área projetual

Depósitos e Armazens para estocagem ou fábricas.







ENTRADA-SAIDA  
DE VEICULOS

TUBOS TRIANG  
INDUSTRIAL  
S.A.

# ESTUDO DO LUGAR

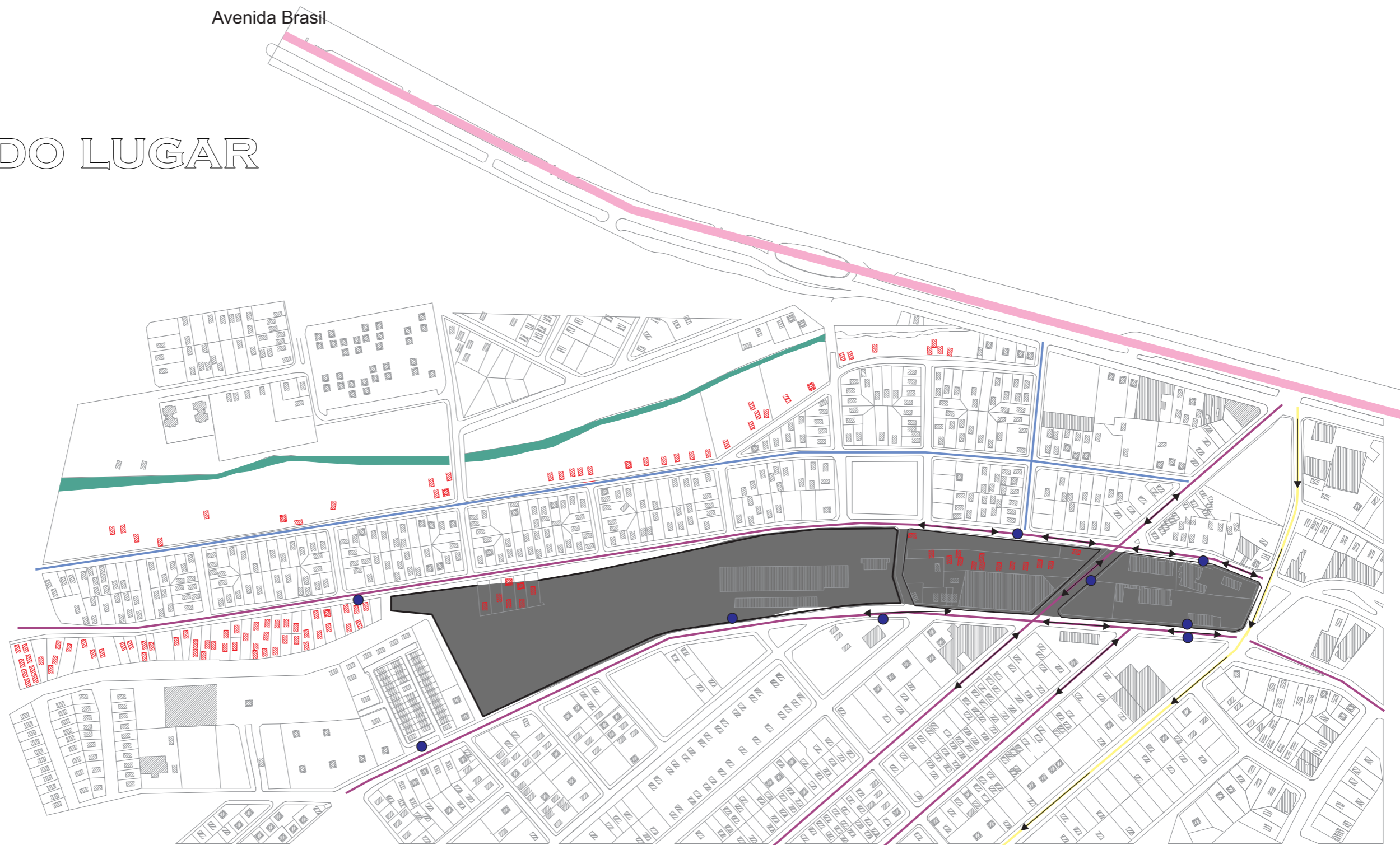

Avenida Brasil



Habitação irregular e área de risco



Via arterial 2ª categoria



Vias coletoras



Vias locais



Avenida Brasil

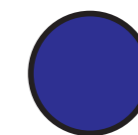

Ponto de parada transporte público.

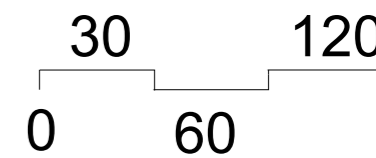



# HABITAÇÃO IRREGULAR E INVASÕES







# HABITAÇÃO IRREGULAR E INVASÕES



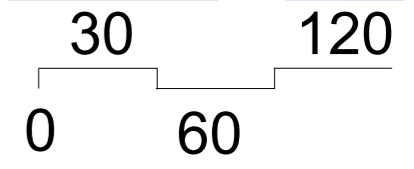

Avenida Brasil

# ESTUDO DO LUGAR



-  Residencial 1 a 4 pv
-  Praça e Área verde
-  Galpões e Armazéns

-  Institucional
-  Comercial
-  Área desocupada

Avenida Brasil

# ○ ESTUDO DO LUGAR

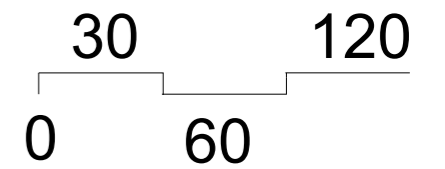
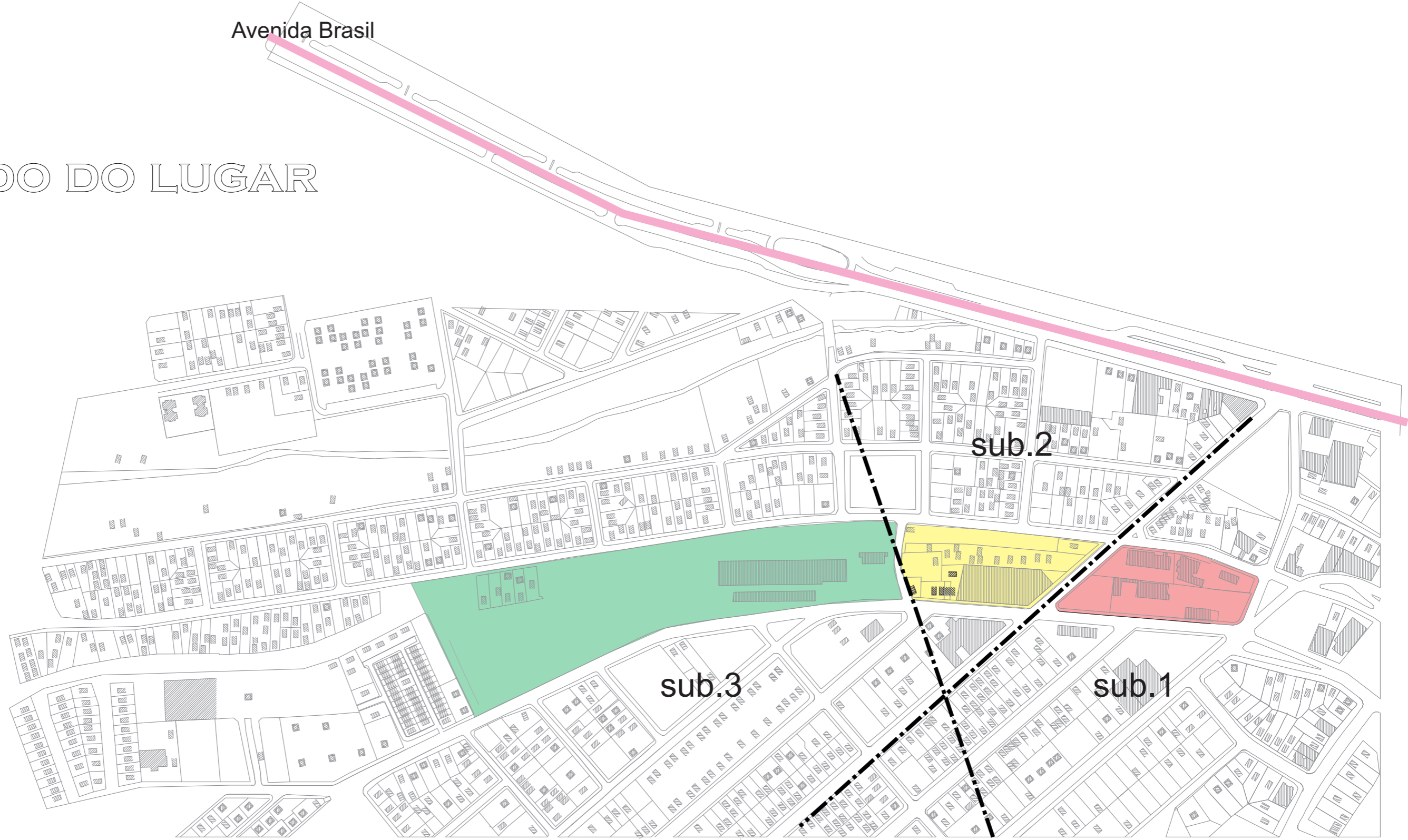

Antigo moinho



Galpões e invasões



Antiga ferrovia

Avenida Brasil

# © ESTUDO DO LUGAR

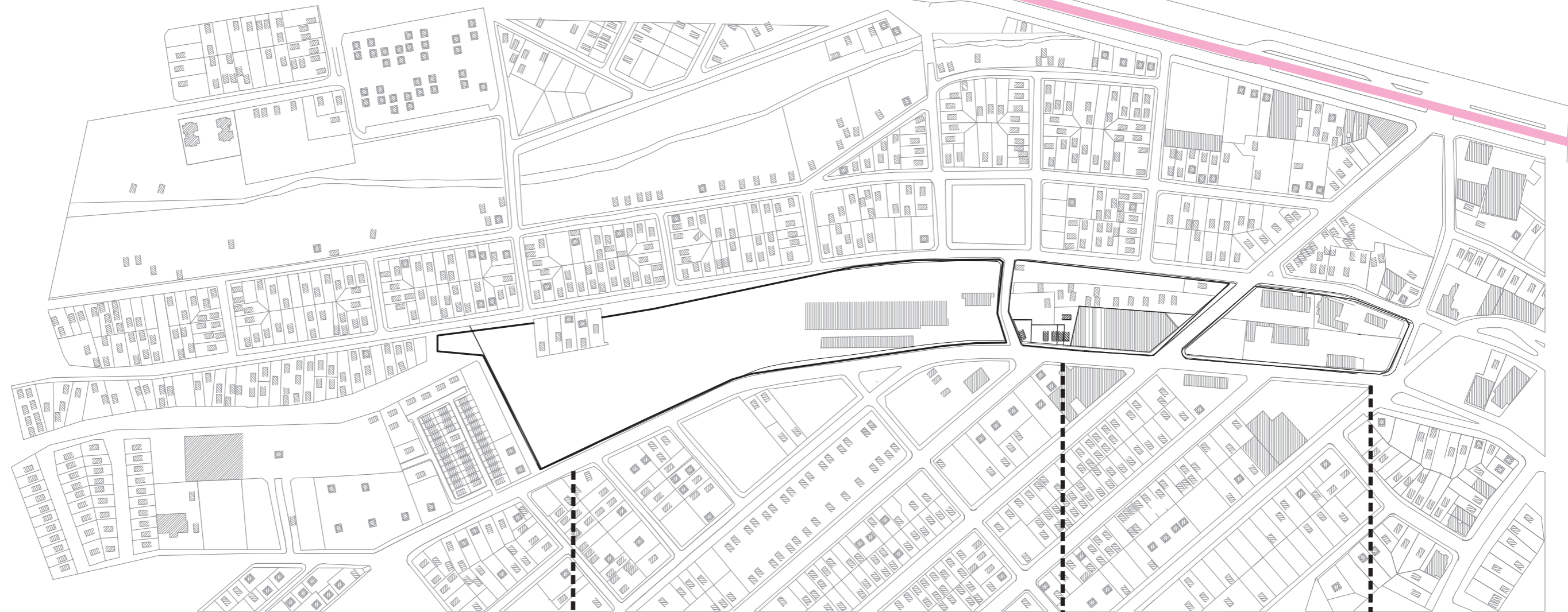

**Usufruir**

-

**Trabalhar**

-

**Residir**

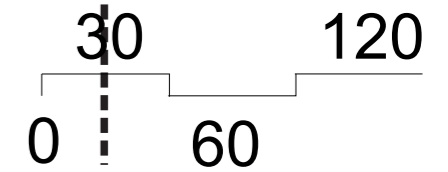

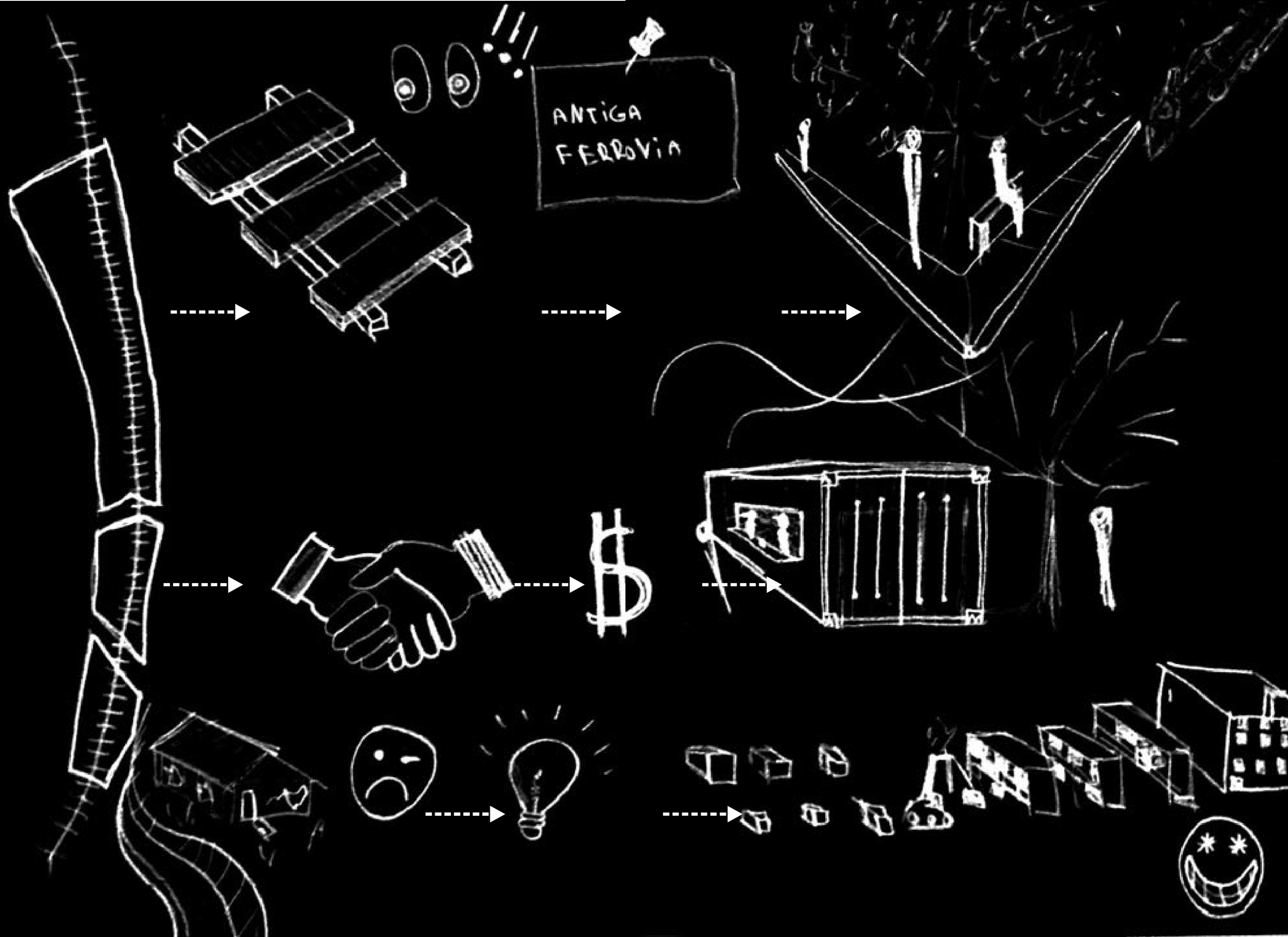

# © TRECHO VILA CONTAINER

Usufruir

Trabalhar

Residir



# O CONTAINER NA HABITAÇÃO





# O BENEFÍCIOS DA CONSTRUÇÃO MODULAR



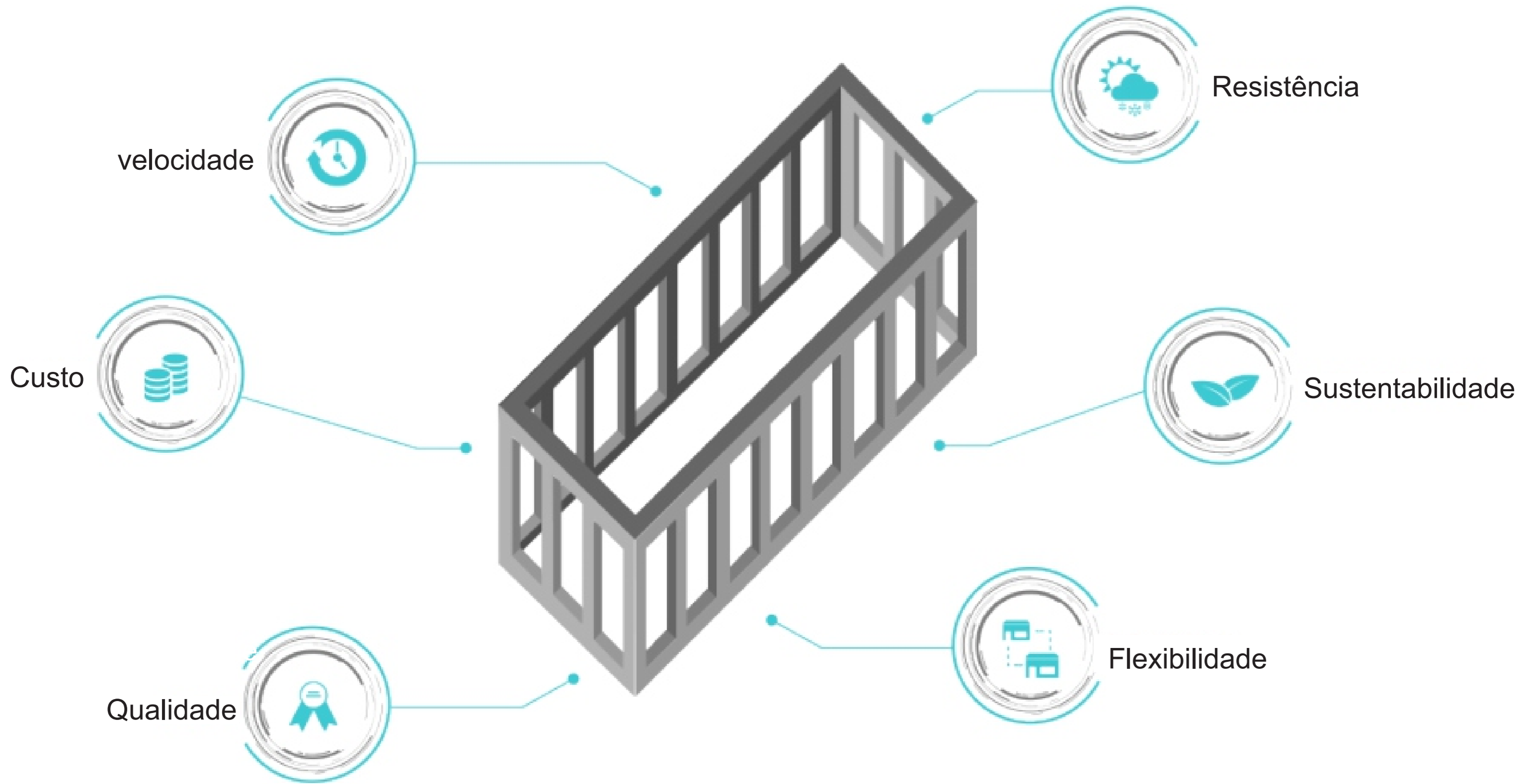

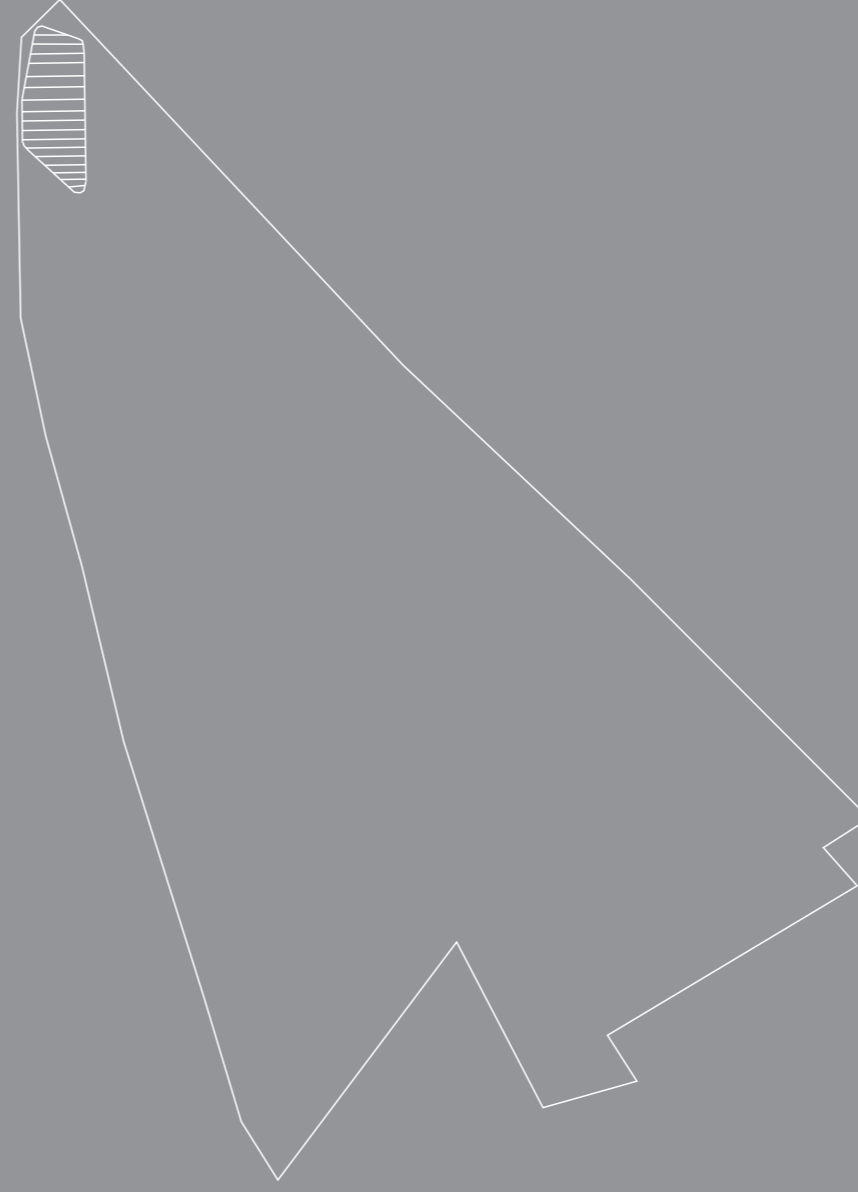
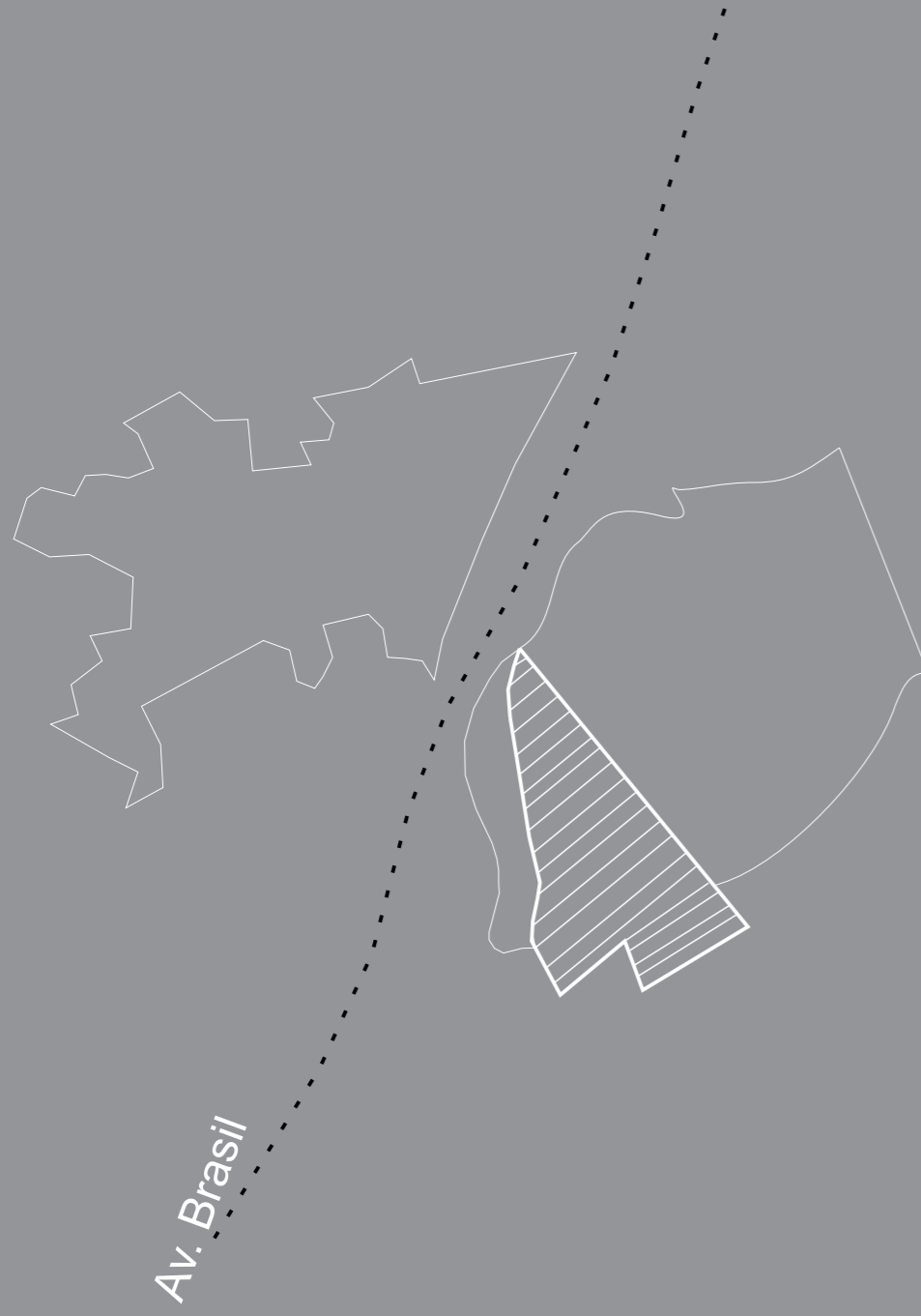

Situação atual

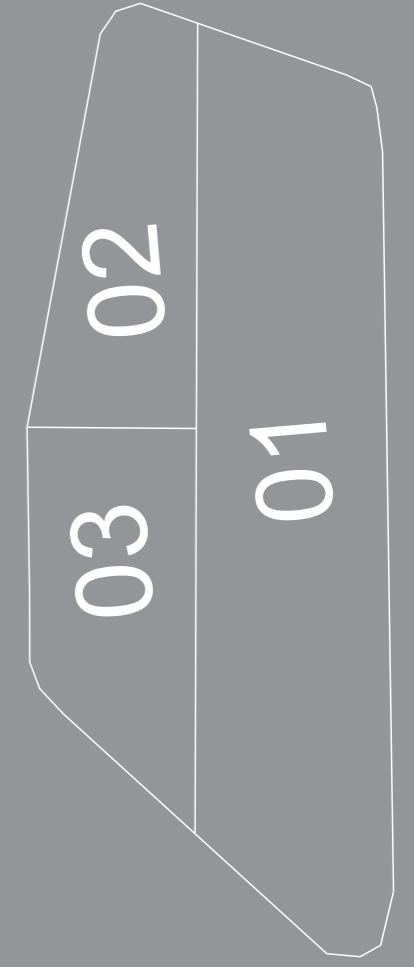

- 1 - Pré -existencia
- 2 - Educação infantil
- 3 - Convivência de idosos

1 - ANTIGO MOINHO . PRÉ - EXISTENCIA.



## 2 - CENTRO MUNICIPAL DE EDUCAÇÃO INFANTIL



### 3 - CENTRO DE CONVIVÊNCIA DE IDOSOS



Kayo Gomes de Souza

# INTERVENÇÕES EM PRÉ-EXISTÊNCIAS

**O antigo moinho**



© EDIFÍCIO PRÉ-EXISTENTE  
A DEGRADAÇÃO





© EDIFÍCIO PRÉ-EXISTENTE  
A DEGRADAÇÃO



# MAPEAMENTO DE DANOS



0 1 2 4 8

Elevação leste

# © PROGRAMA

Antigo moinho  
catarinense - **1.520**  
**m<sup>2</sup>**

Institucional - **290**  
**m<sup>2</sup>**

Público - **1.015**  
**m<sup>2</sup>**

Circulação - **215**  
**m<sup>2</sup>**

Habitação de interesse  
social -  
**6.264 m<sup>2</sup>**

Habitacional - **4.216 m<sup>2</sup>**  
Circulação - **2.048 m<sup>2</sup>**

Estacionamento e circulação de veículos-  
**4.086 m<sup>2</sup>**

Praças e contemplação -  
**4.570 m<sup>2</sup>**

Habitação social  
Circulação  
Praças  
Convivência de idosos

Educação infantil  
Exposição de arte e história 1  
Exposição de arte e história 2  
Espaço de eventos



© PROGRAMA  
HABITAÇÃO SOCIAL

Habitação social  
4.216 M<sup>2</sup>

Circulação  
2.048 M<sup>2</sup>

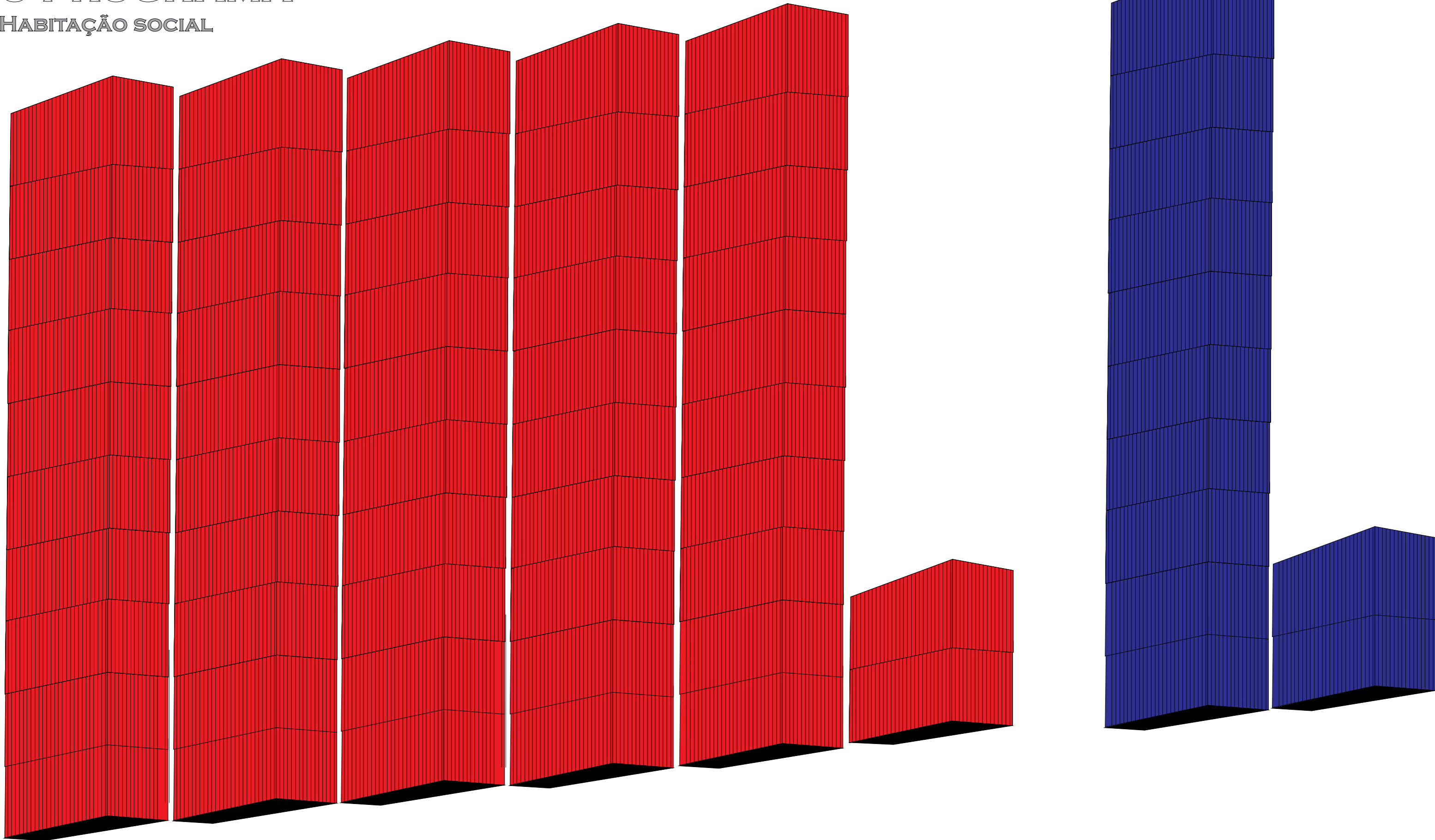

# © PROGRAMA

## PRÉ EXISTENCIA

Café  
70 M<sup>2</sup>

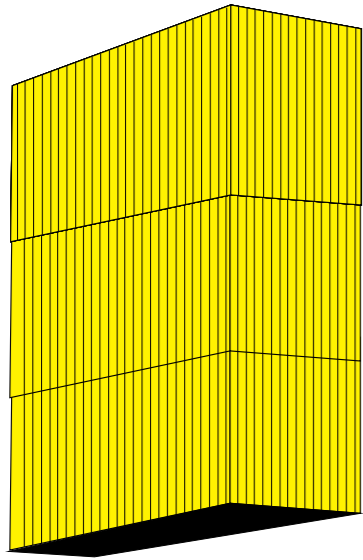

Centro de convivencia de  
idosos  
143,33 M<sup>2</sup>

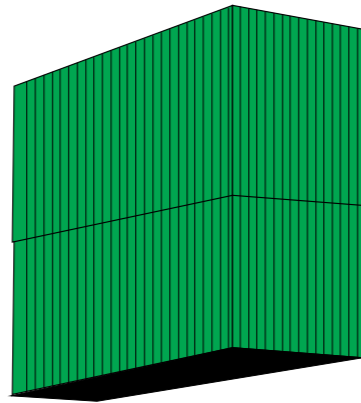

Ensino infantil  
160,33 M<sup>2</sup>

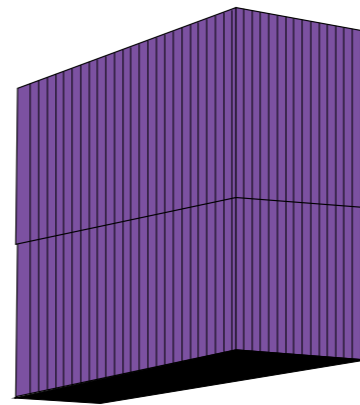

Exposição 1  
285 M<sup>2</sup>

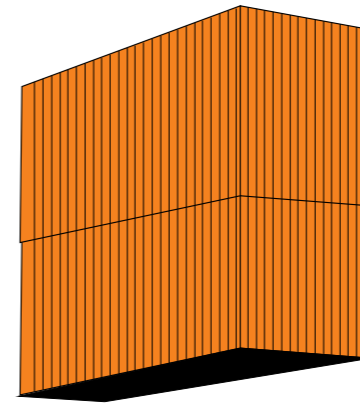

Exposição 2  
285 M<sup>2</sup>

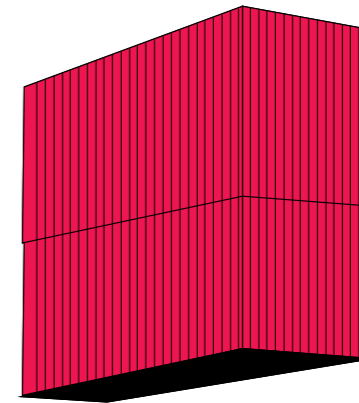

Salão de  
eventos  
285 M<sup>2</sup>

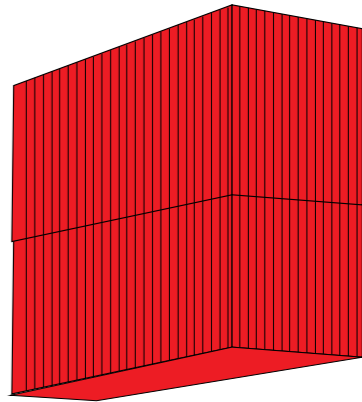

Recepção  
33 M<sup>2</sup>

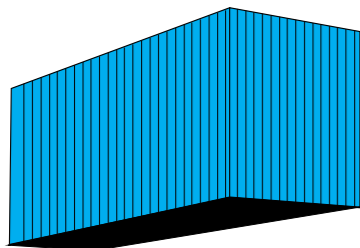

W.C  
140,40 M<sup>2</sup>

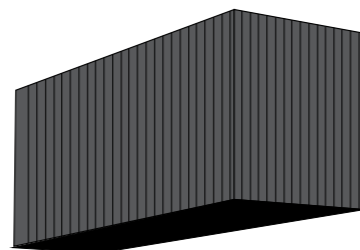

© PROJETO



# DIAGRAMA DE CONCEITO E VOLUME

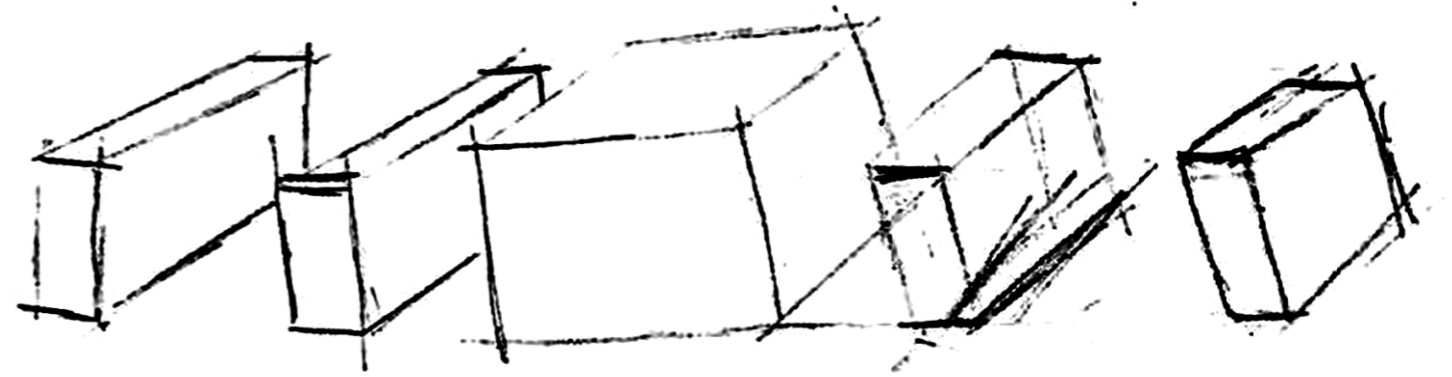
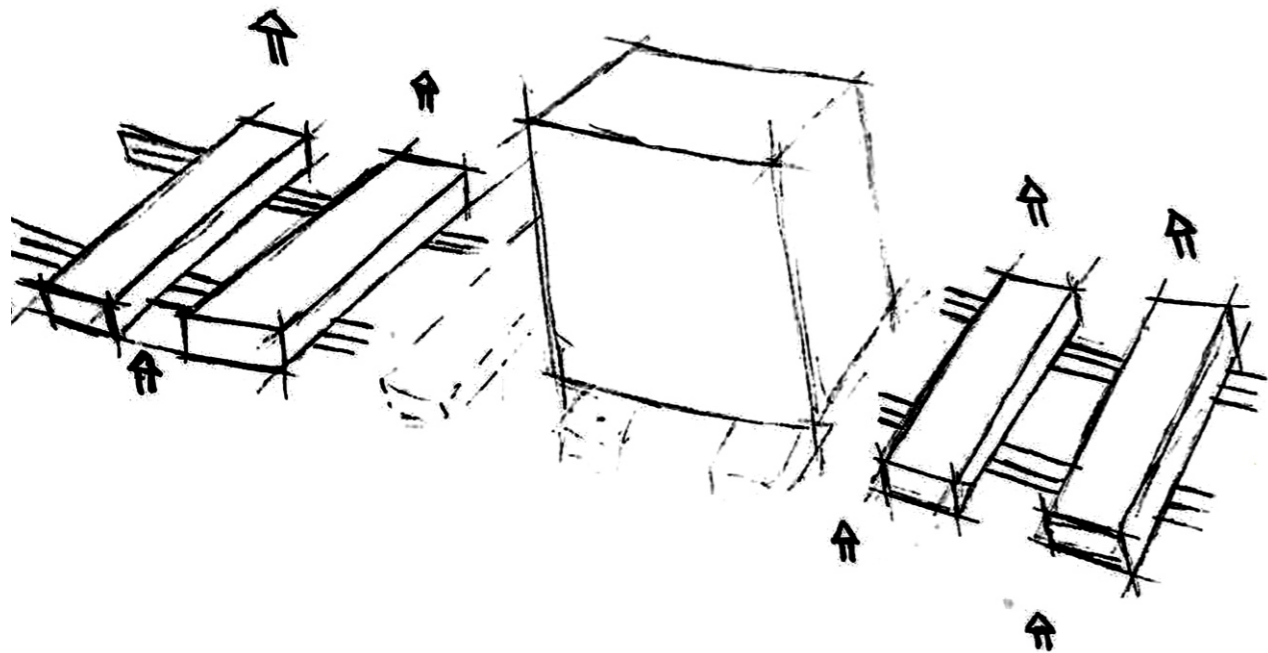
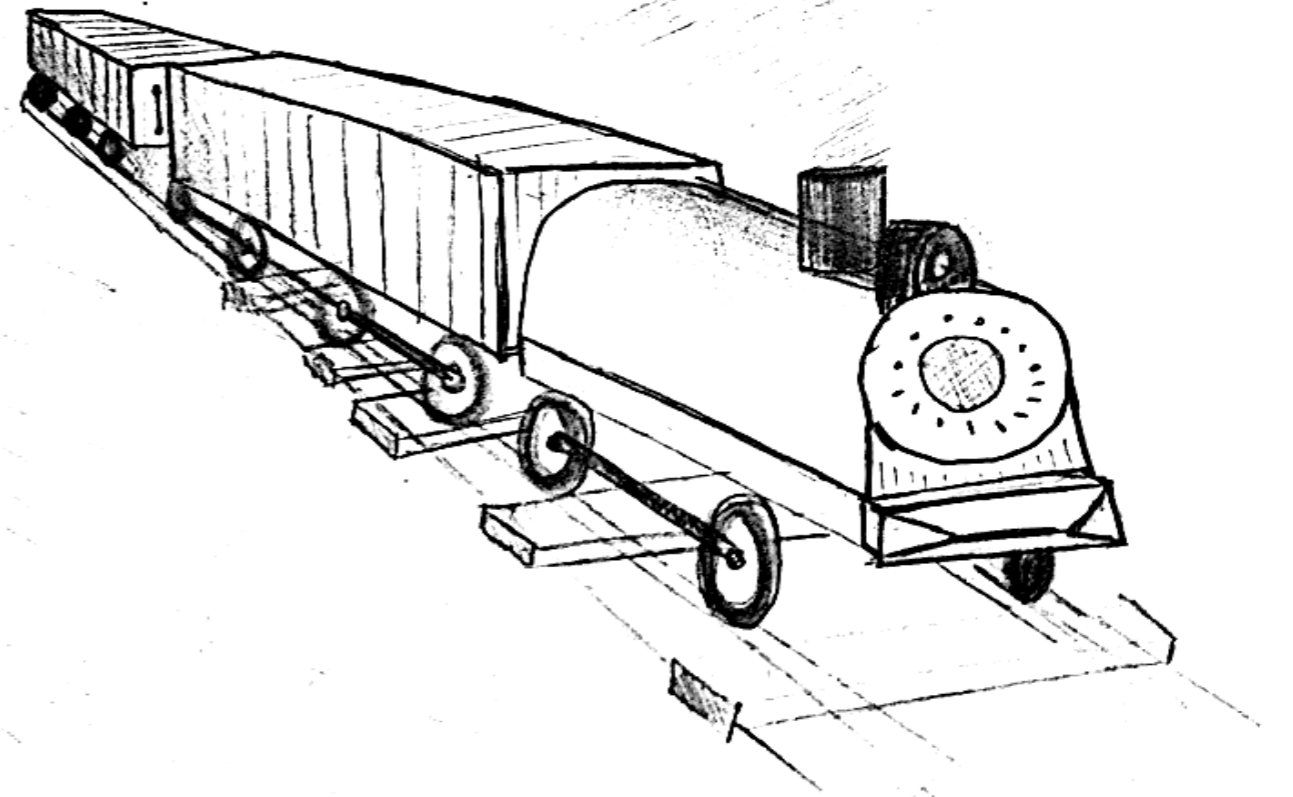



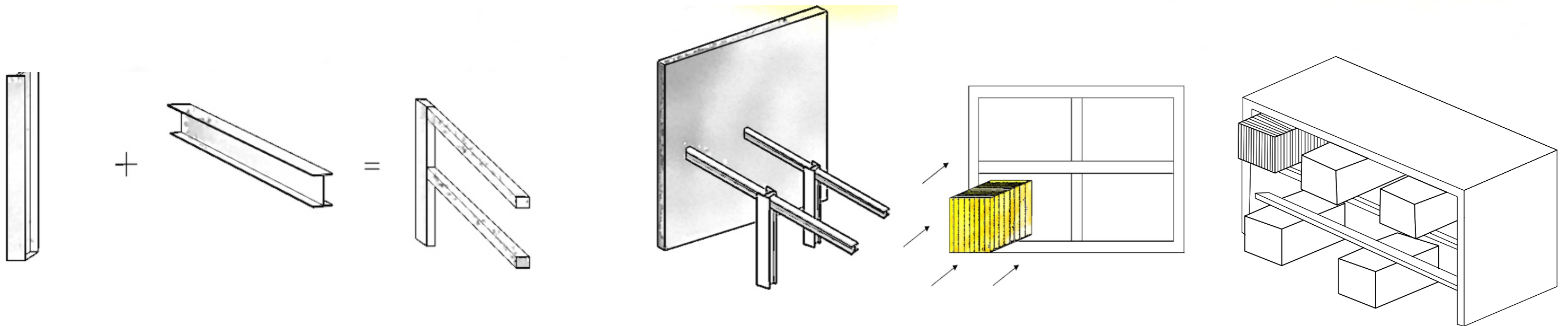
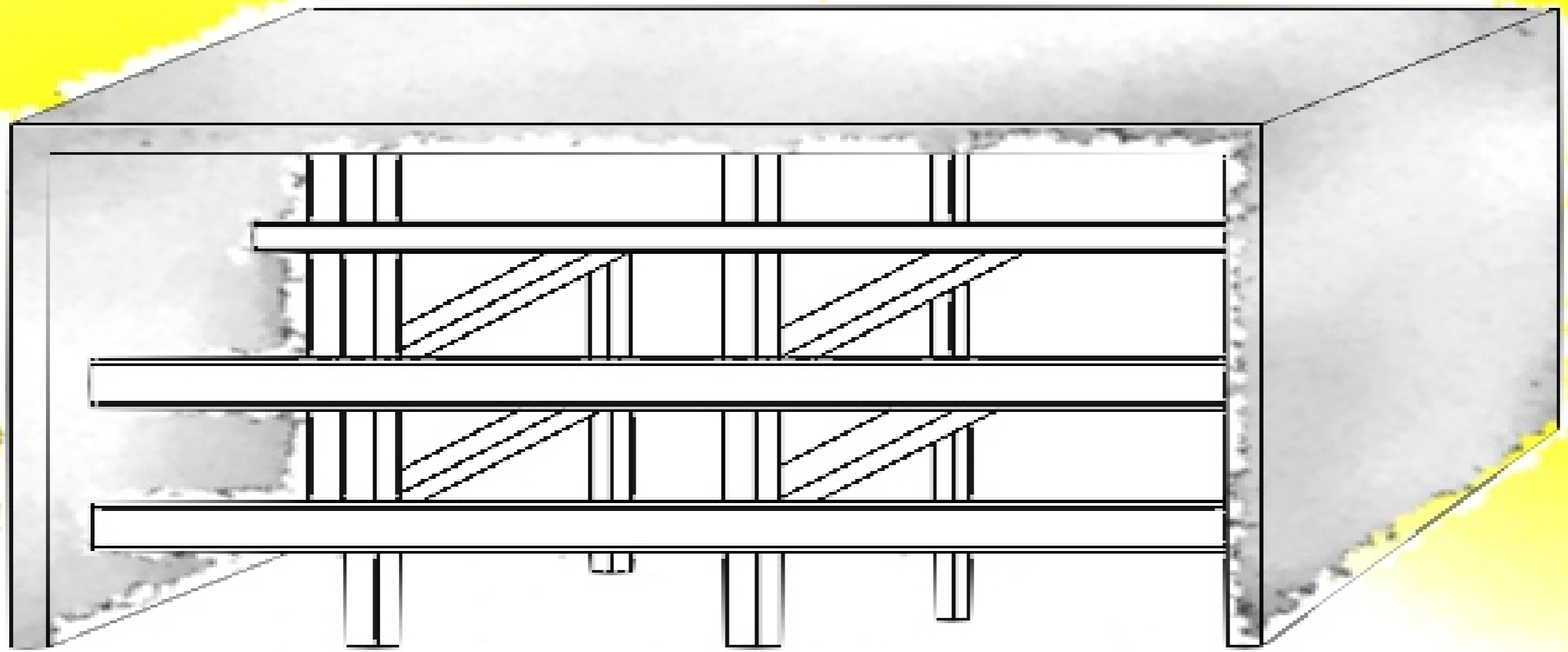

# DIAGRAMA DE LOCAÇÃO

X

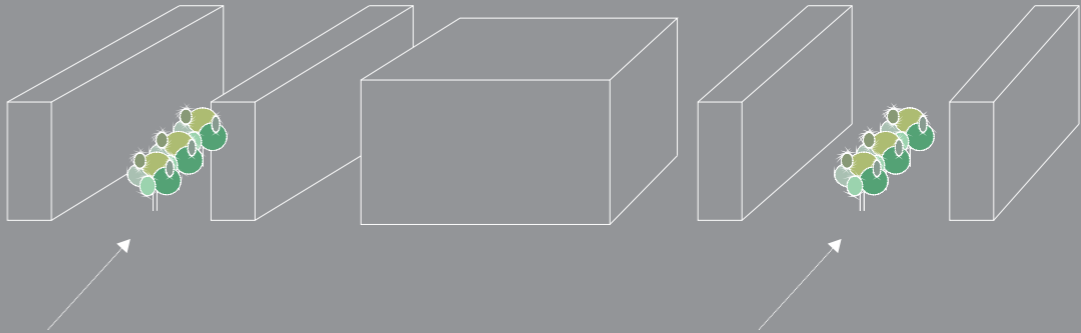
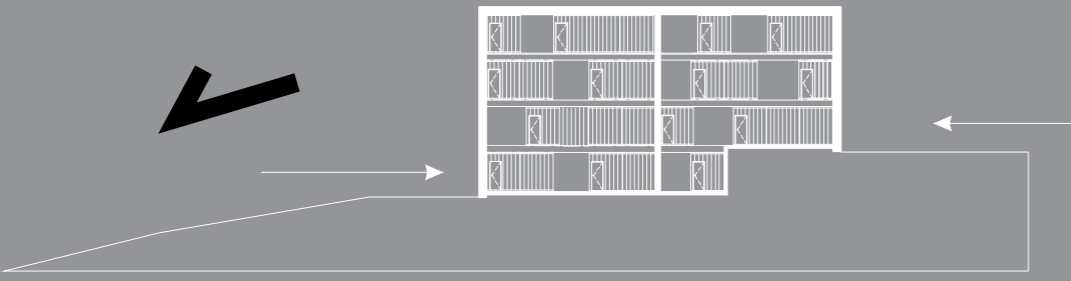

# ESTUDO DA FACHADA

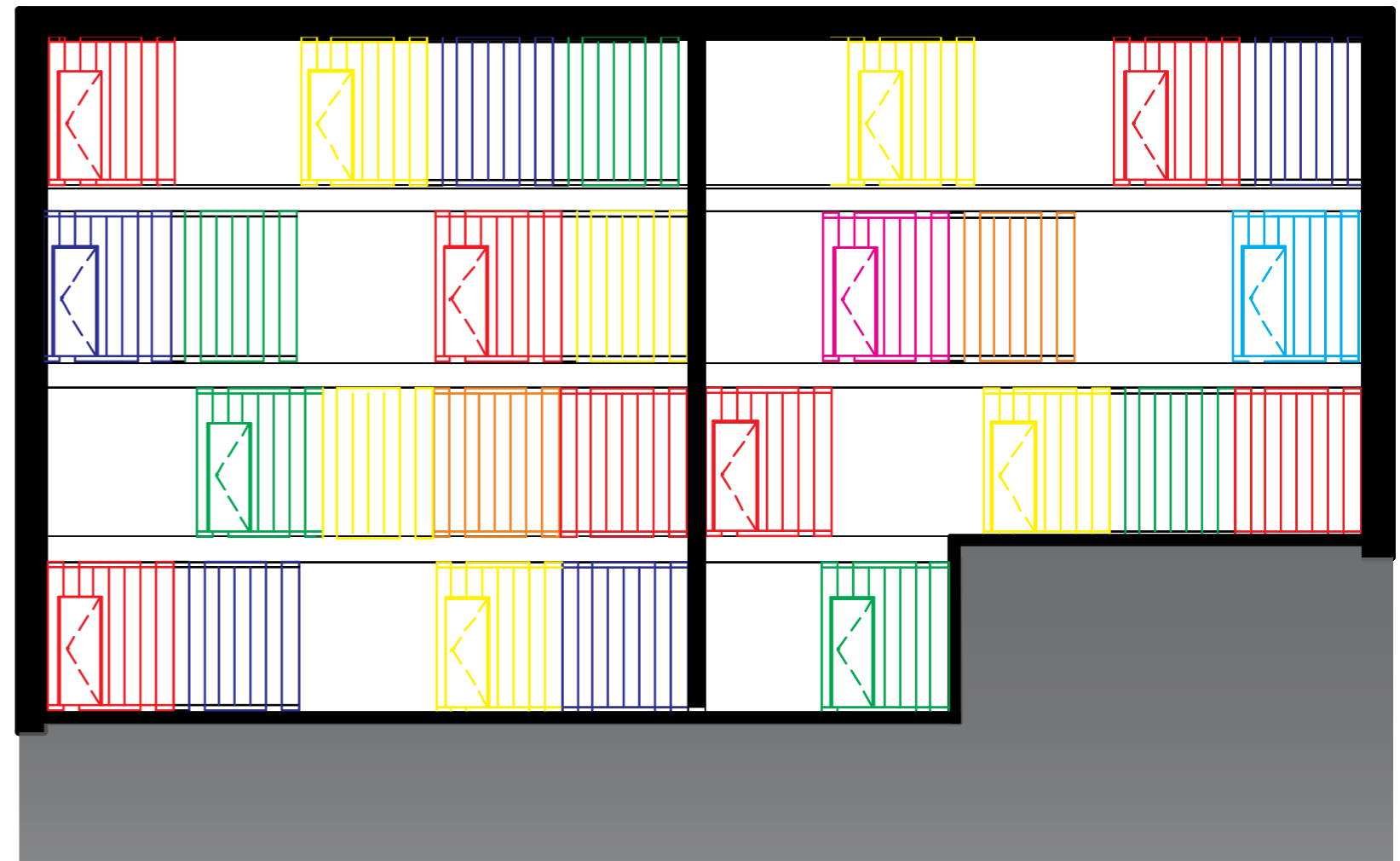
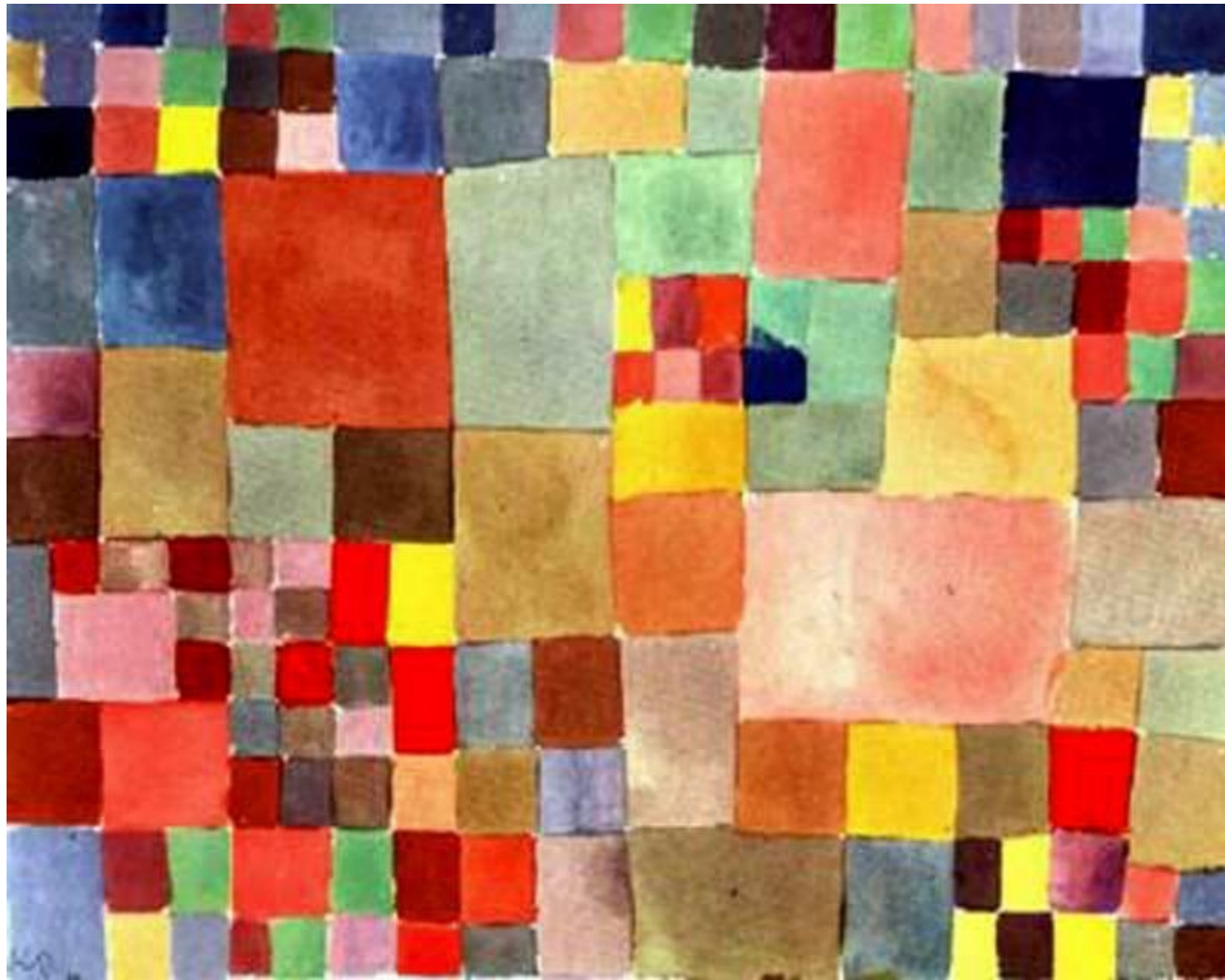



O PROJETO

BSIU 225378 8  
22G1

MAX. GROSS	30.480	KGS
	67.200	LBS
TARE	2.185	KGS
	4.820	LBS
NET	28.295	KGS
	62.380	LBS
CU. CAP.	33.2	CUM.
	1.173	CUFT.



VILA  
CONTAINER

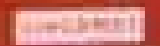
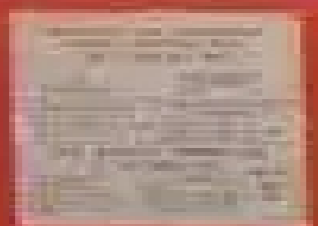

# MODELO DE PLANTAS

Planta 1 container

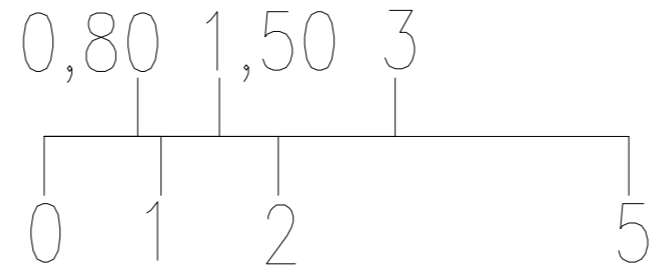
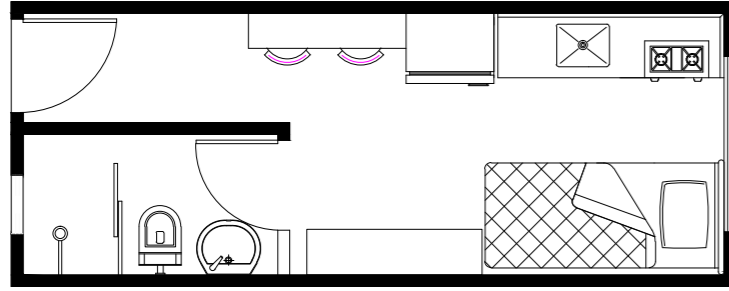

Planta 2 container

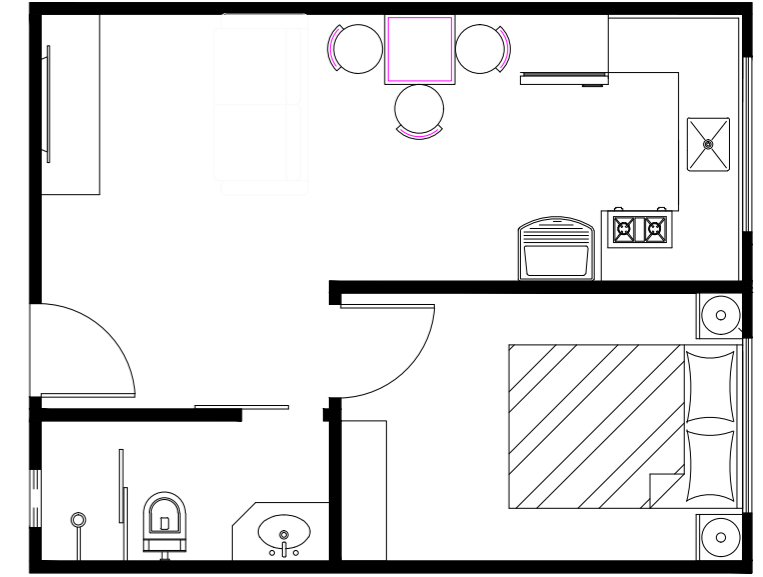

Planta 3 container

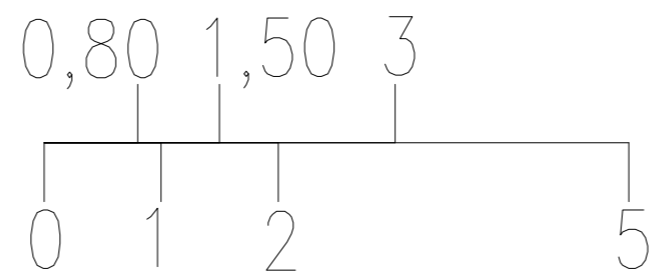
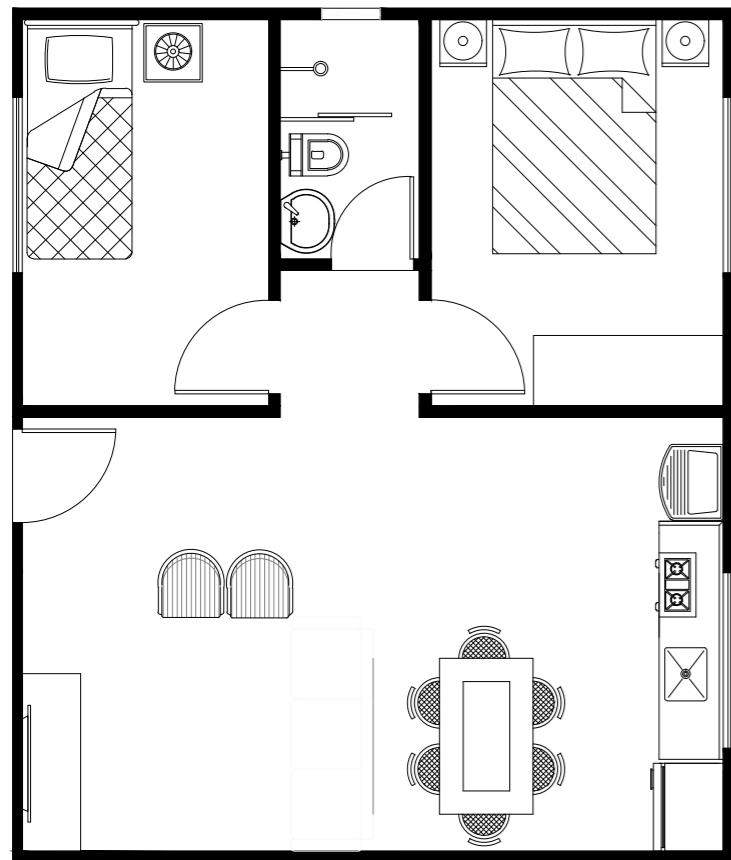

Planta 4 container

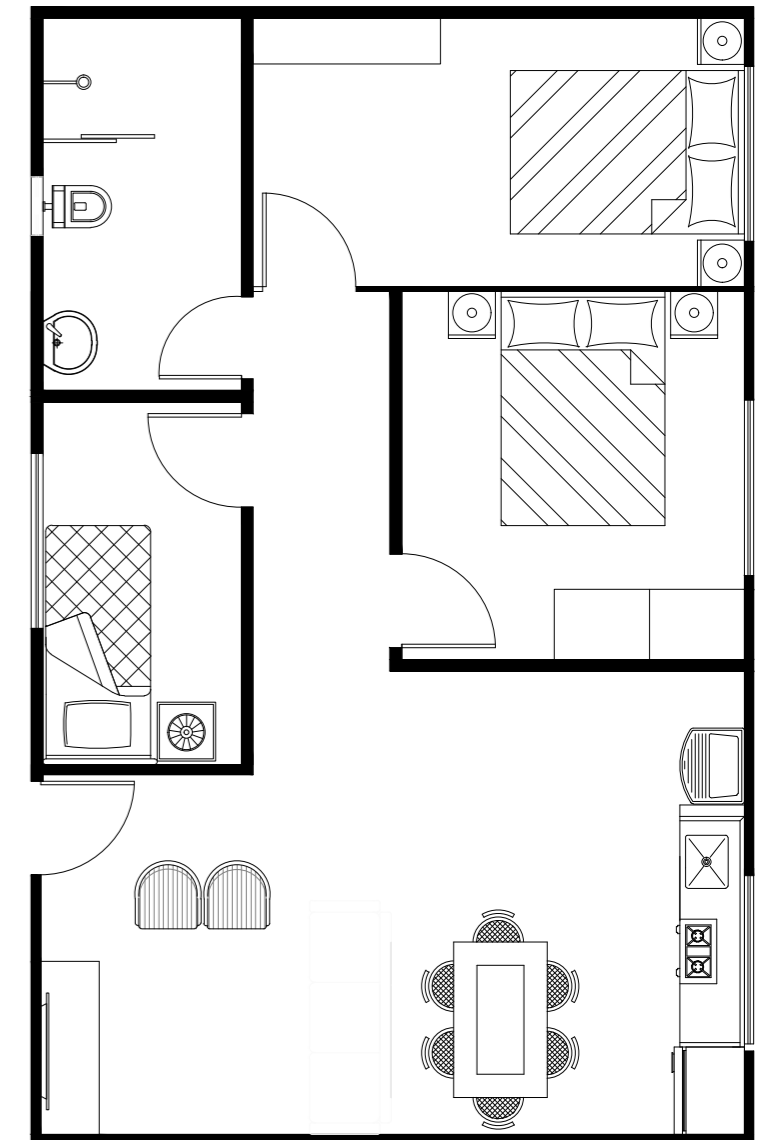

1001 1000.50 1000

# IMPLANTAÇÃO

1001.50  
1002  
1002.50  
1003

1000  
1000.50  
1001  
1001.50  
1002  
1002.50  
1003



- 1 - Apartamento 1 container
- 2 - Apartamento 2 containers
- 3 - Apartamento 3 containers
- 4 - Apartamento 4 containers
- 5 - Praça interna
- 6 - Praça
- 7 - estacionamento

- 8 - Acesso pedestres
- 9 - Acesso veículos
- 10 - Saída veículos
- 11 - Talude
- 12 - Hall
- 13 - Espera
- 14 - Cafeteria

## IMPLANTAÇÃO E TÉRREO Nível 2

- 15 - Escada de emergencia
- 16 - Elevadores
- 17 - Escada comum
- 18 - D.M.L
- 19 - Sala de informatica
- 20 - Sala de corte e costura
- 21 - Sala de artesanato
- 22 - Atendimentos médicos

- 23 - Fisioterapia
- 24 - Odontologia
- 25 - Banheiro Masculino
- 26 - Banheiro Feminino

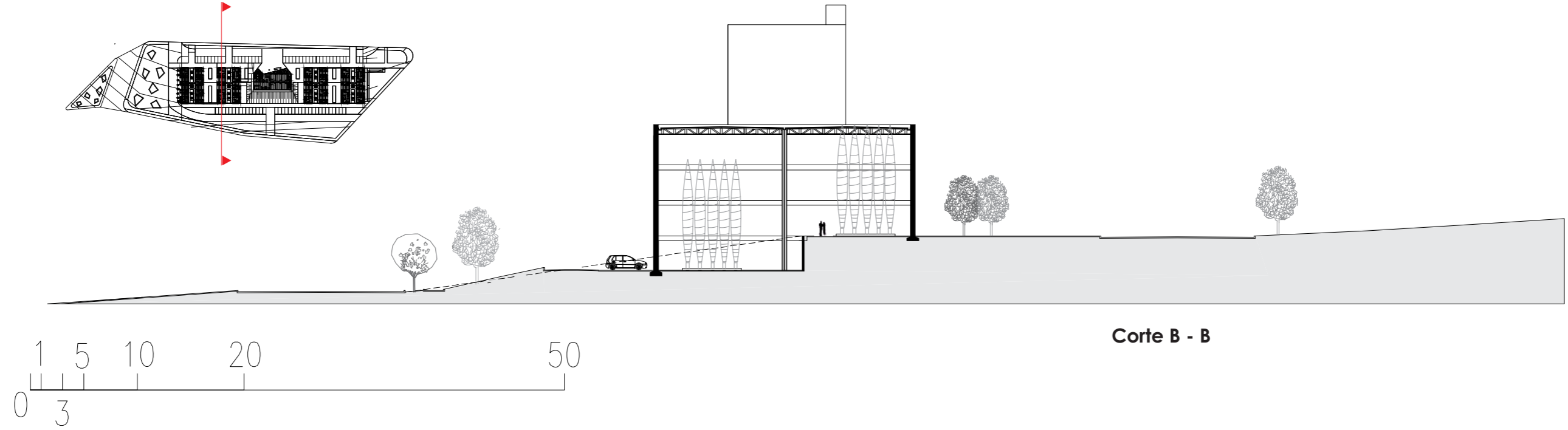

Corte B - B

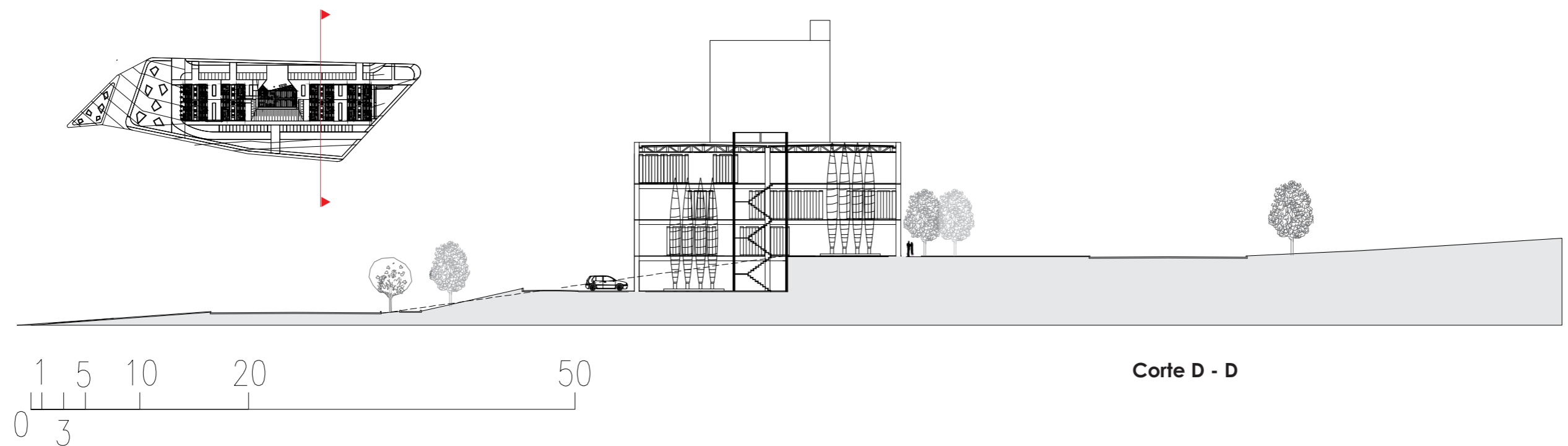

Corte D - D

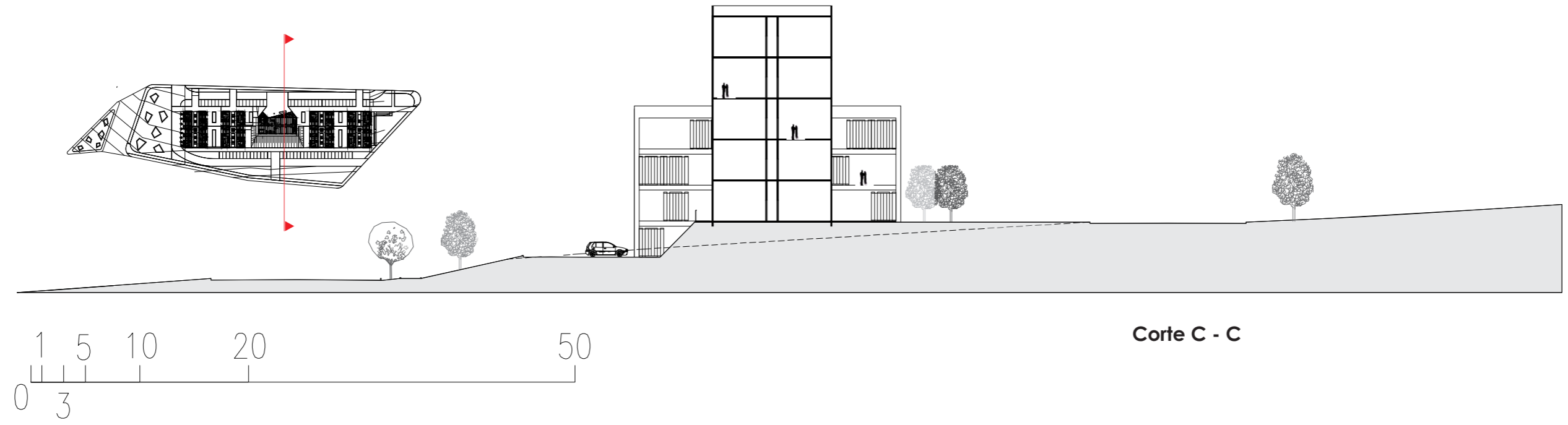

Corte C - C



- 1 - Escada de acesso habitação
- 2 - Praças internas
- 3 - Praças externas
- 4 - Área coberta comum
- 5 - Estacionamento
- 6 - Saída de veículos
- 7 - Acesso pedestre

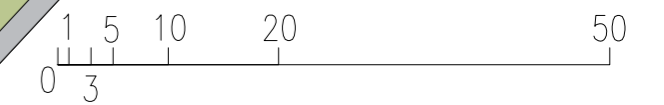

Nível 1  
Nível +1003

**Habitação nível inferior**



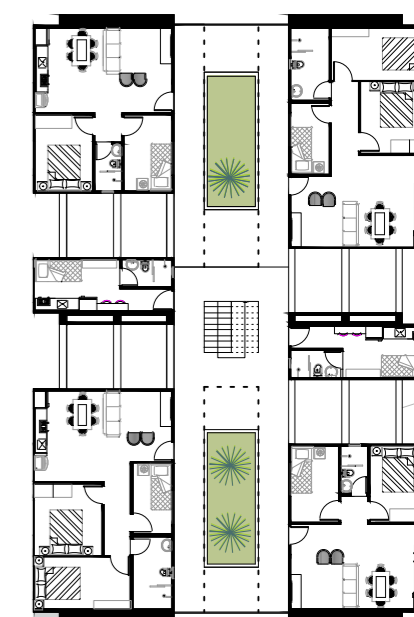
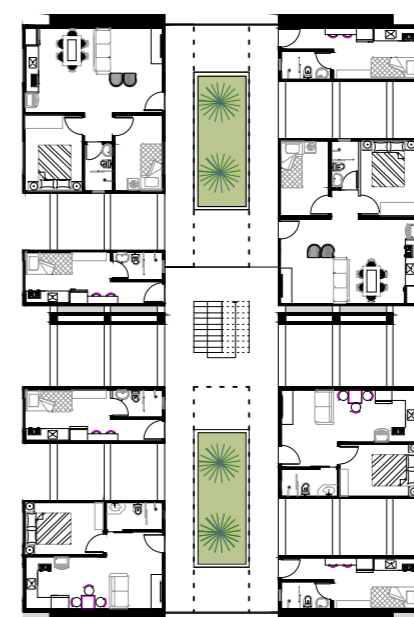
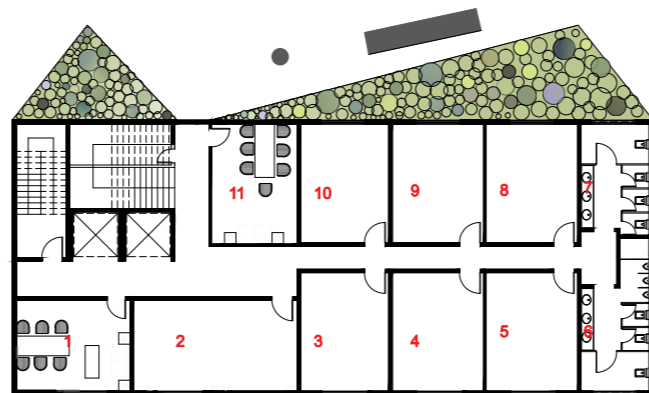
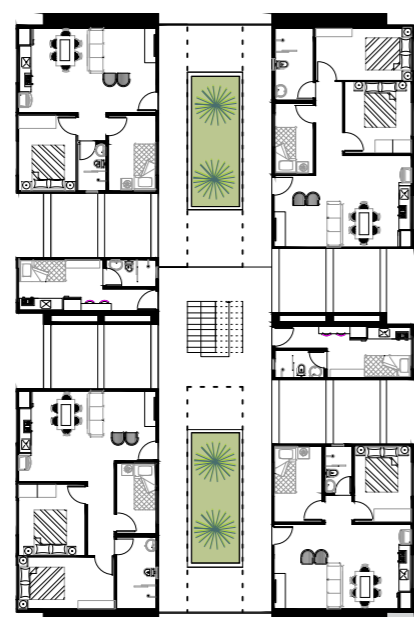
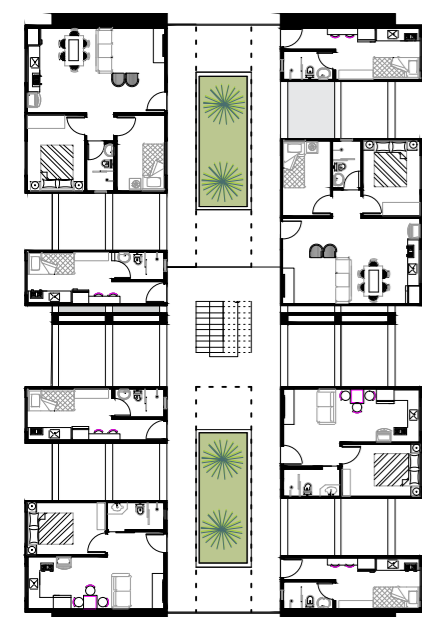

- 1 - Sala dos professores
- 2 - Brinquedoteca
- 3 - Aula 1
- 4 - Aula 2
- 5 - Aula 3
- 6 - Banheiro feminino
- 7 - Banheiro Masculino
- 8 - Aula 4
- 9 - Aula 5
- 10 - Aula 6
- 11 - Sala de reunião

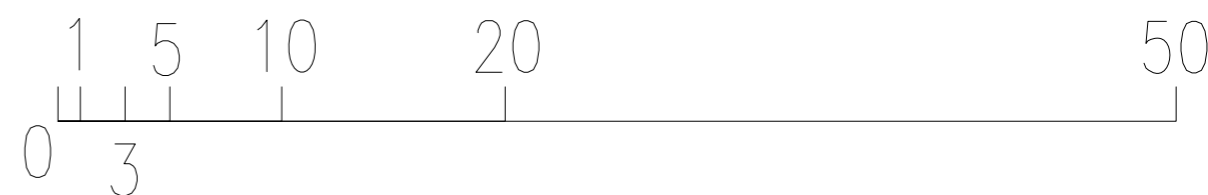

Nível 3

### Habitação e Educação infantil

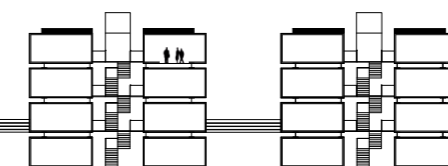
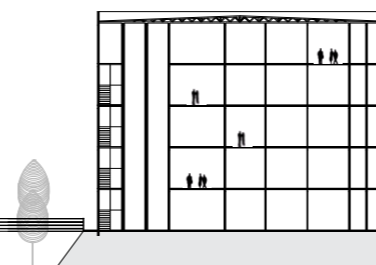
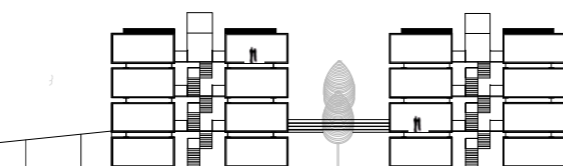
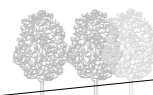
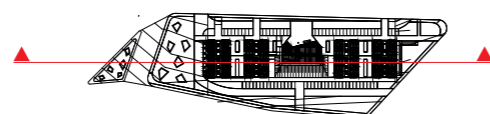

Corte A - A

Kayo Gomes de Souza

Habitação Social - Vila Container

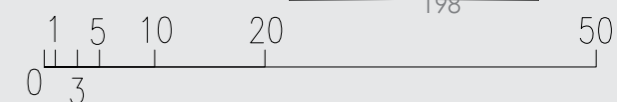

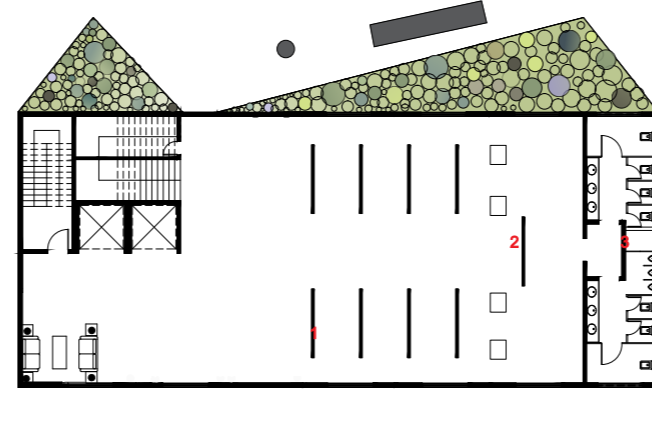
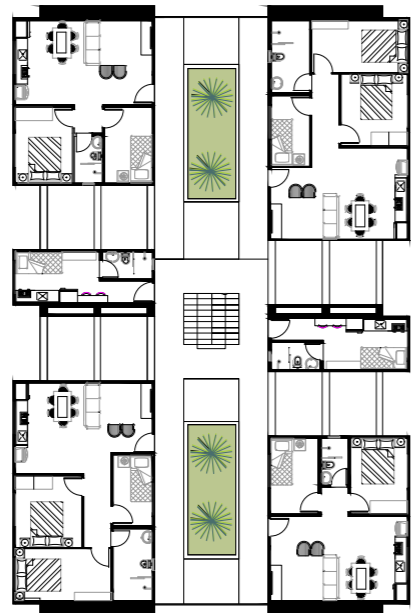
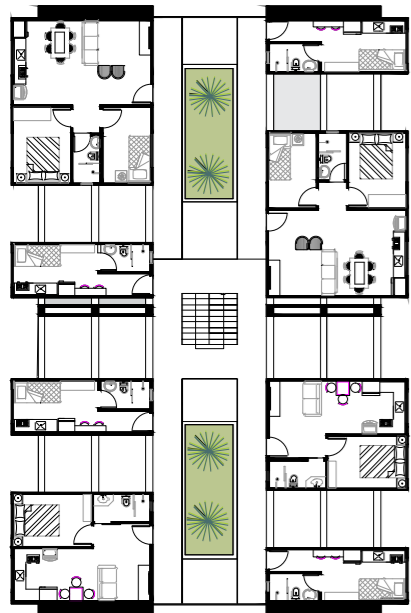

5

4

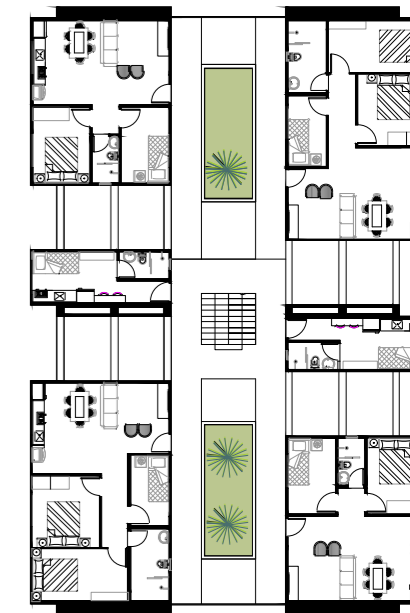
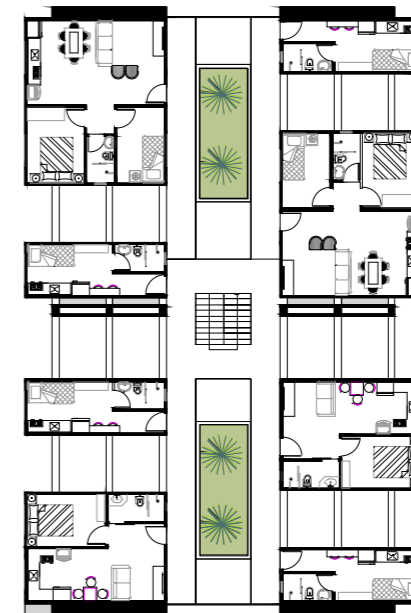

- 1 - Ambiente de estar
- 2 - Exposição em painéis
- 3 - Exposição de estátuas
- 4 - Banheiro Feminino
- 5 - Banheiro Masculino

Nível 4

### Habitação e Espaço de exposições I

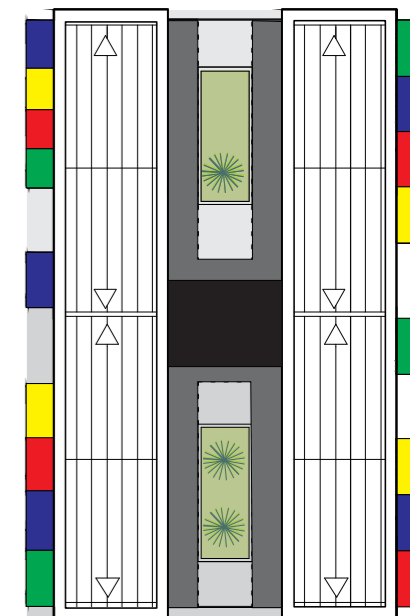
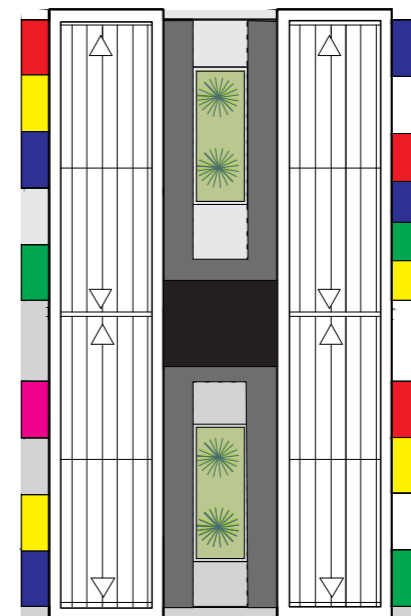
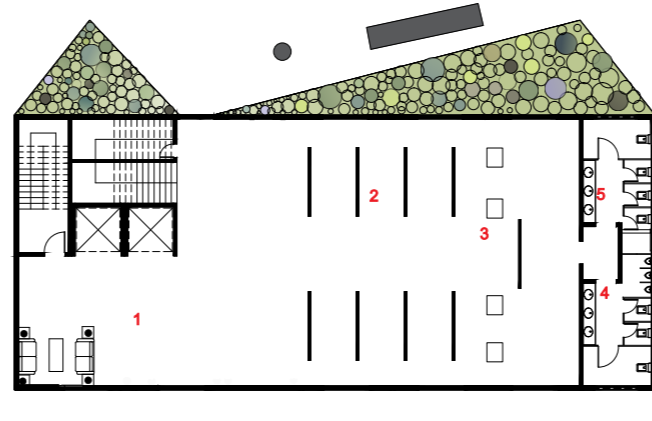
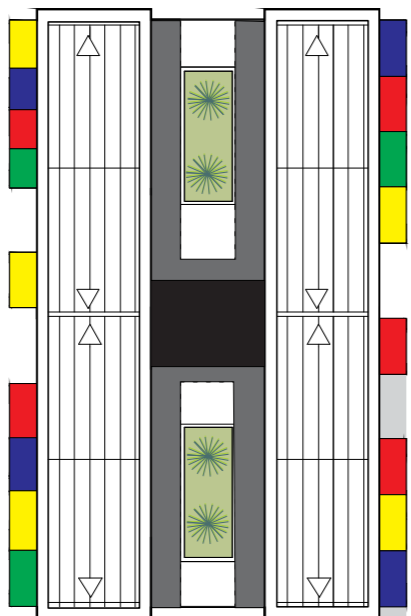
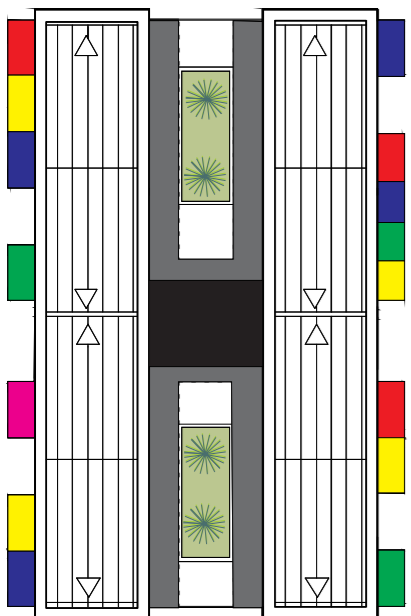
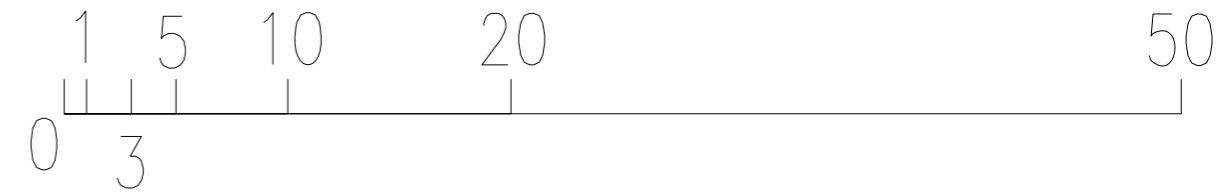

- 1 - Ambiente de estar
- 2 - Exposição em painéis
- 3 - Exposição de estátuas
- 4 - Banheiro Feminino
- 5 - Banheiro Masculino

Nível 5

### Espaço de exposições II



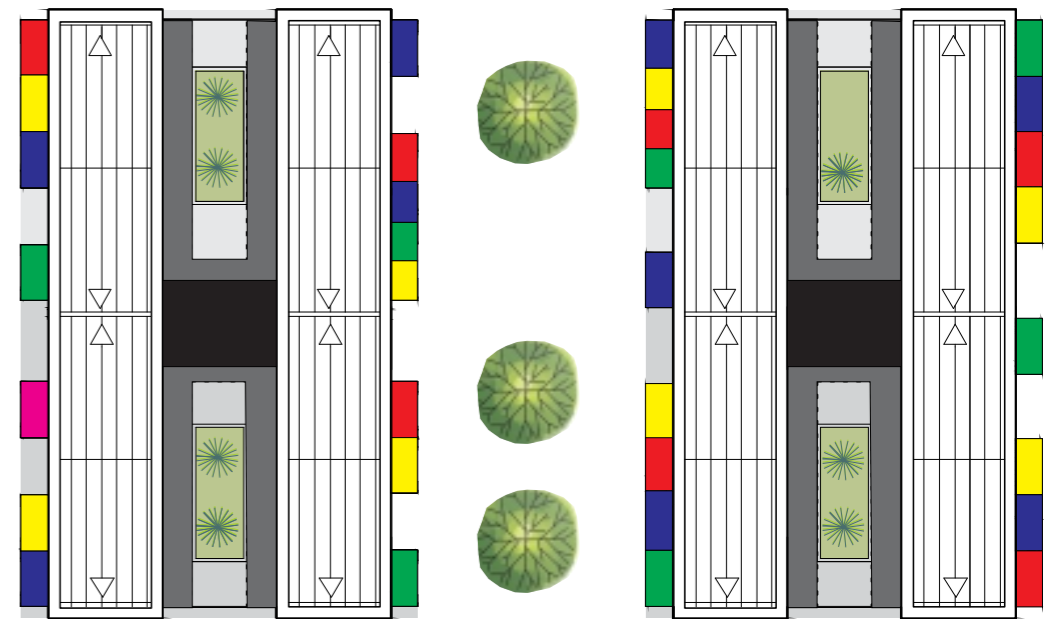
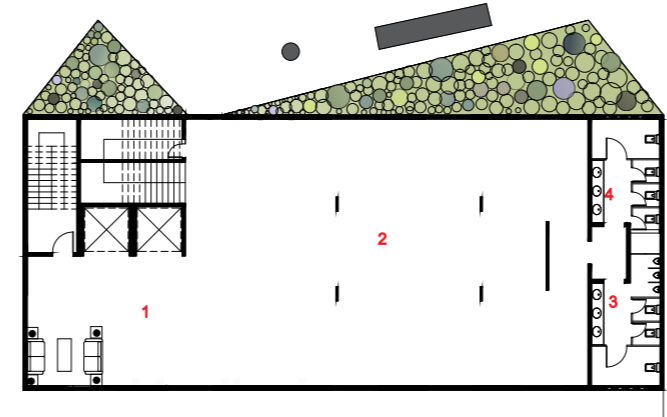
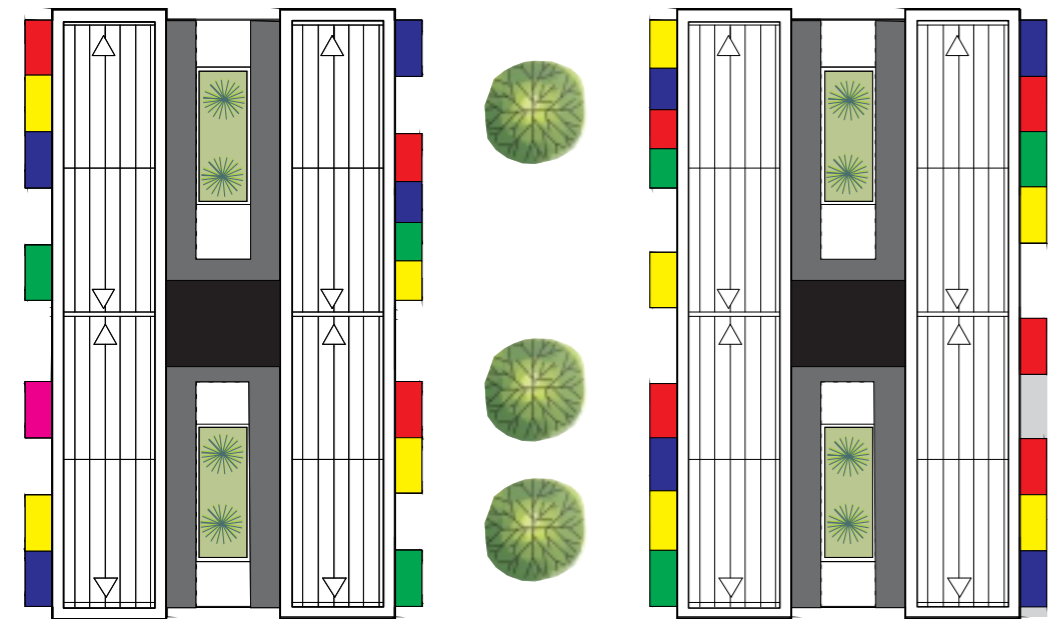

- 1 - Ambiente de estar
- 2 - Espaço para eventos
- 3 - Banheiro Feminino
- 4 - Banheiro Masculino

Nível 6

Salão de eventos

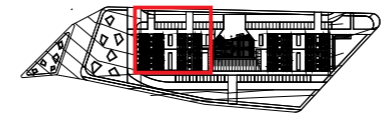

- 1 - Praça interna.
- 2 - Praça externa.
- 3 - Passarela de acesso.
- 4 - Circulação vertical.
- 5 - Acesso pedestres

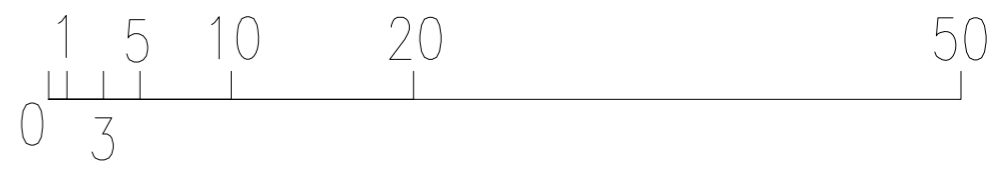

# © DESENHO DAS FACHADAS

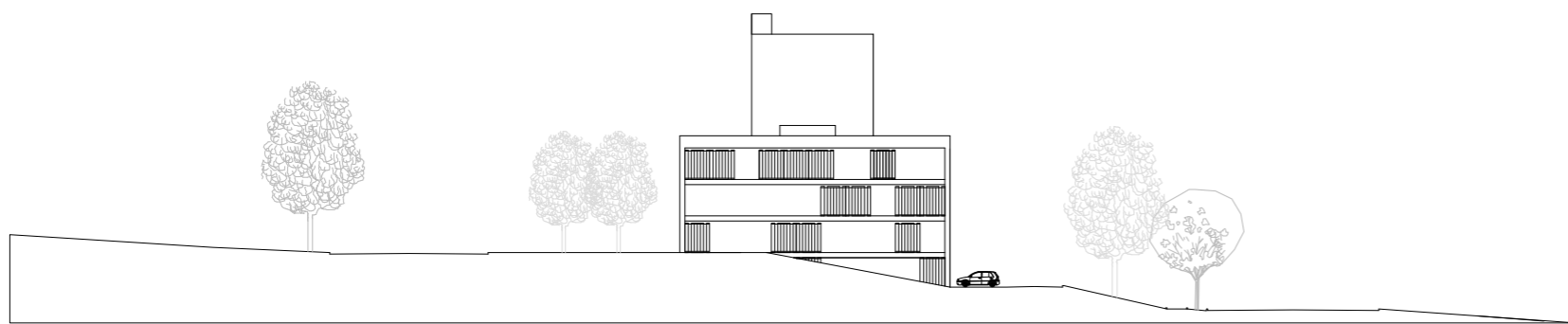

Elevação Norte

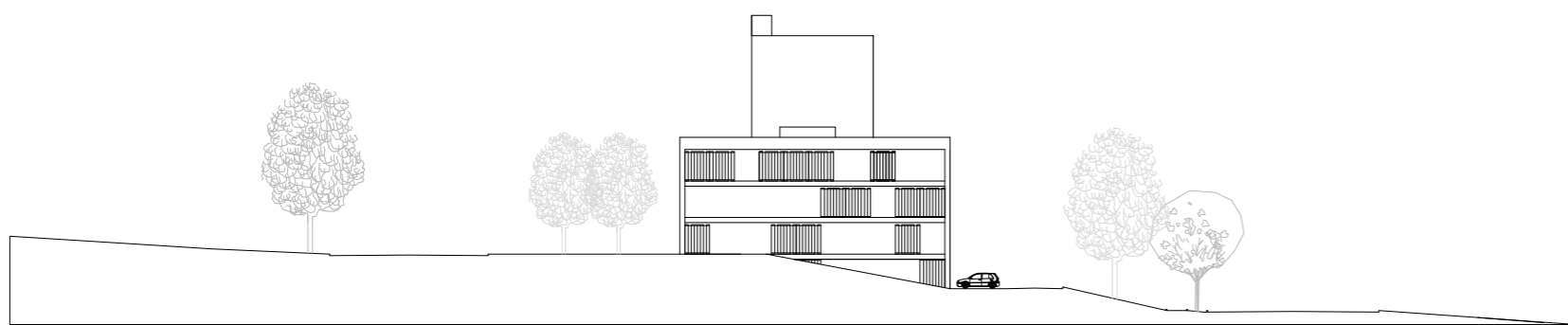

Elevação Sul

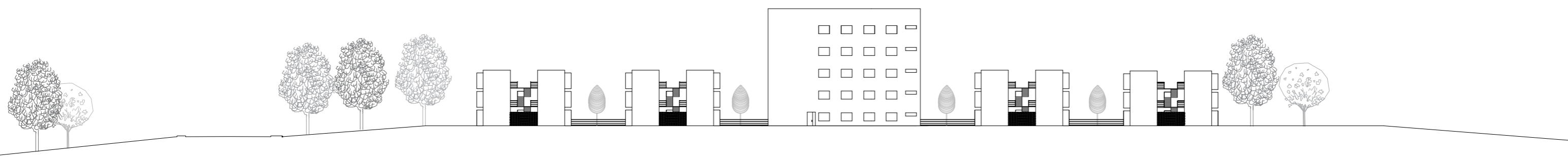

Elevação Leste

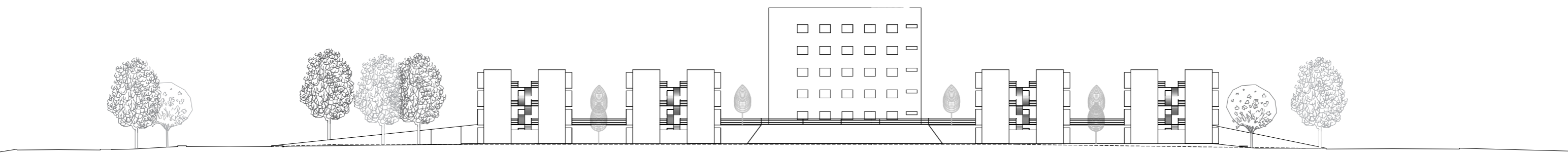

Elevação Oeste





# DETALHAMENTO

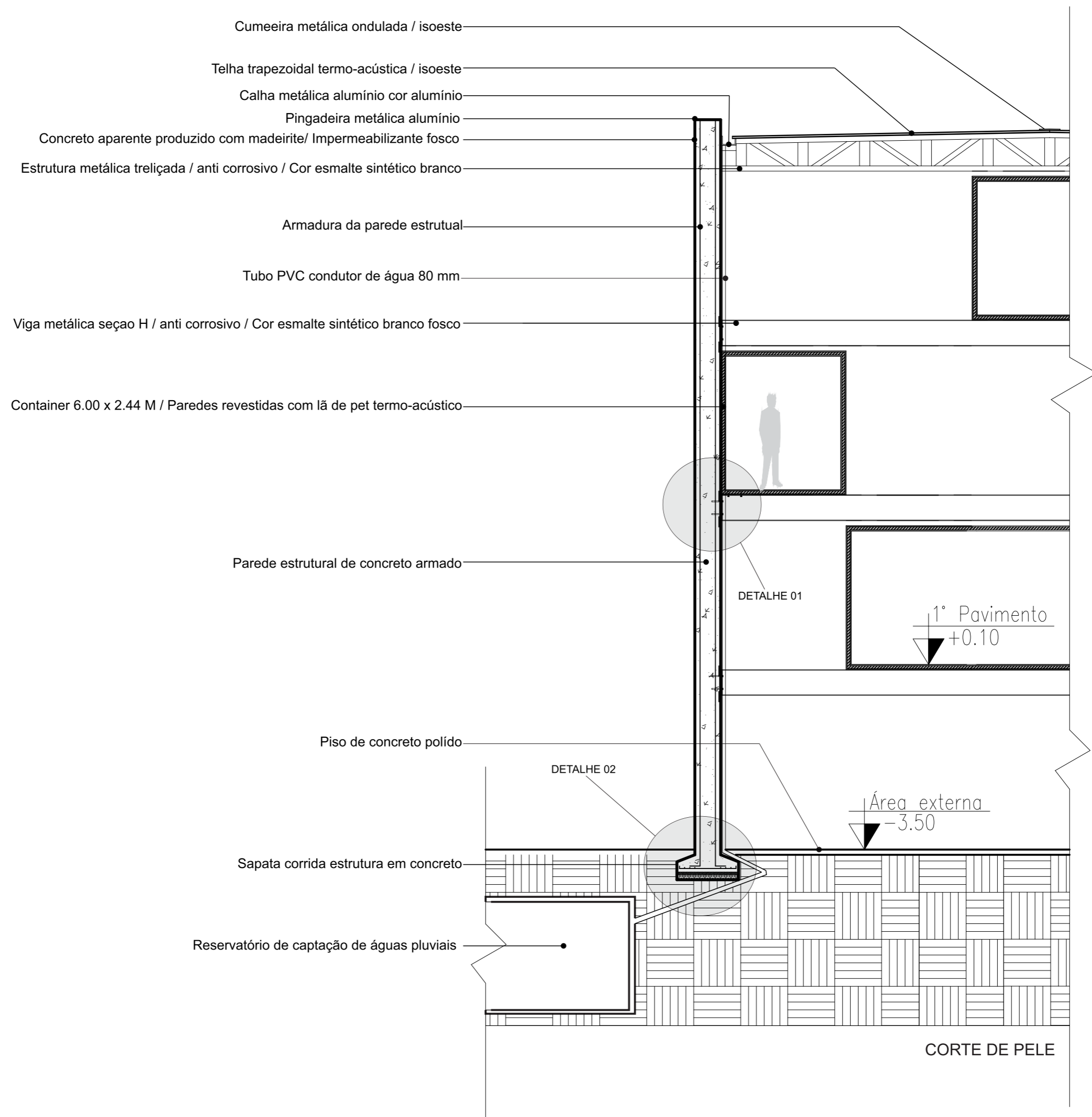

- Cumeeira metálica ondulada / isoeste
- Telha trapezoidal termo-acústica / isoeste
- Calha metálica alumínio cor alumínio
- Pingadeira metálica alumínio
- Concreto aparente produzido com madeirite/ Impermeabilizante fosco
- Estrutura metálica treliçada / anti corrosivo / Cor esmalte sintético branco
- Armadura da parede estrutural
- Tubo PVC condutor de água 80 mm
- Viga metálica seção H / anti corrosivo / Cor esmalte sintético branco fosco
- Container 6.00 x 2.44 M / Paredes revestidas com lã de pet termo-acústico

Parede estrutural de concreto armado

Piso de concreto polido

Sapata corrida estrutura em concreto

Reservatório de captação de águas pluviais

DETALHE 01

DETALHE 02

1º Pavimento  
+0.10

Área externa  
-3.50

CORTE DE PELE

# DETALHES ESPECÍFICOS

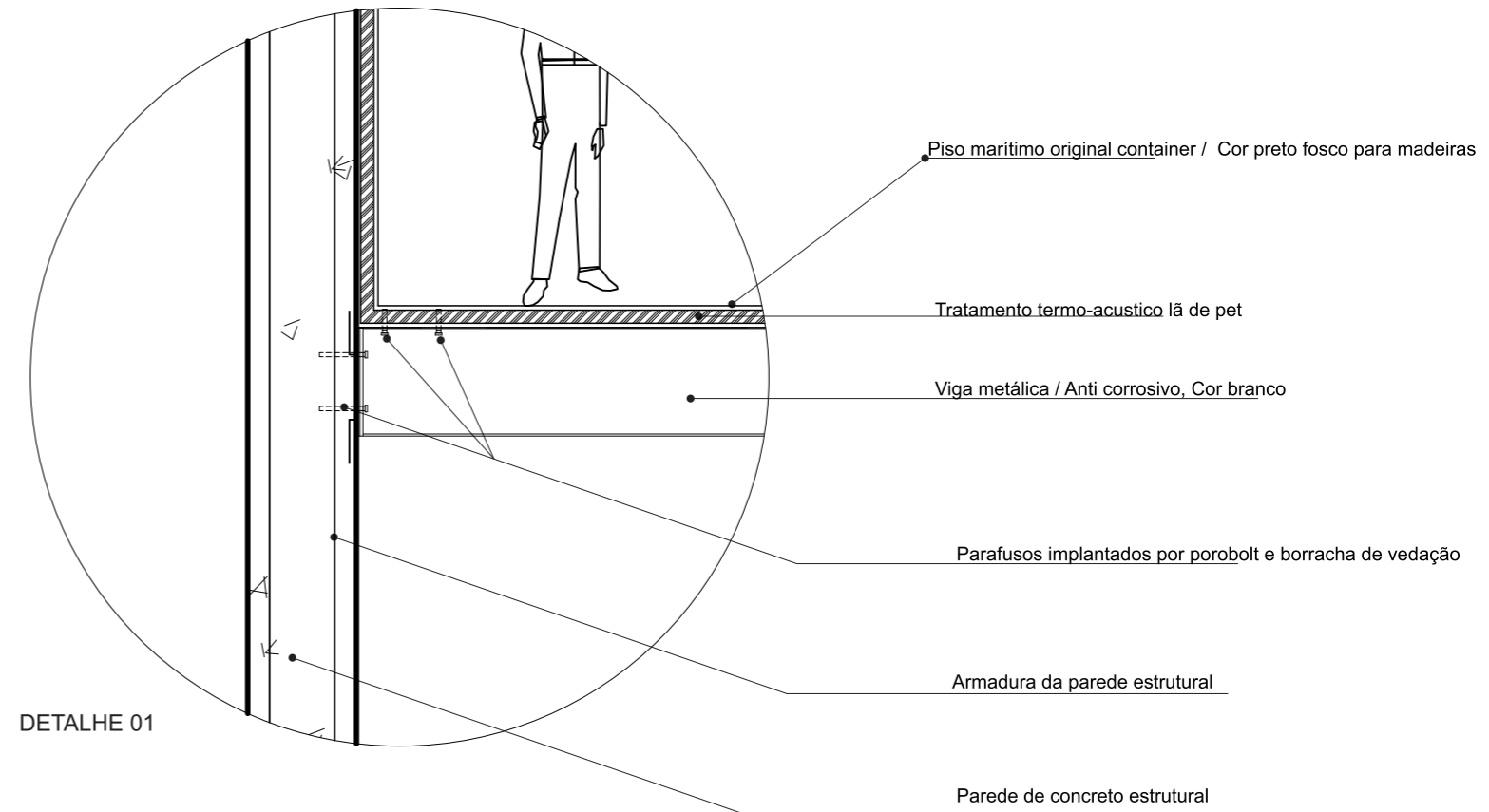
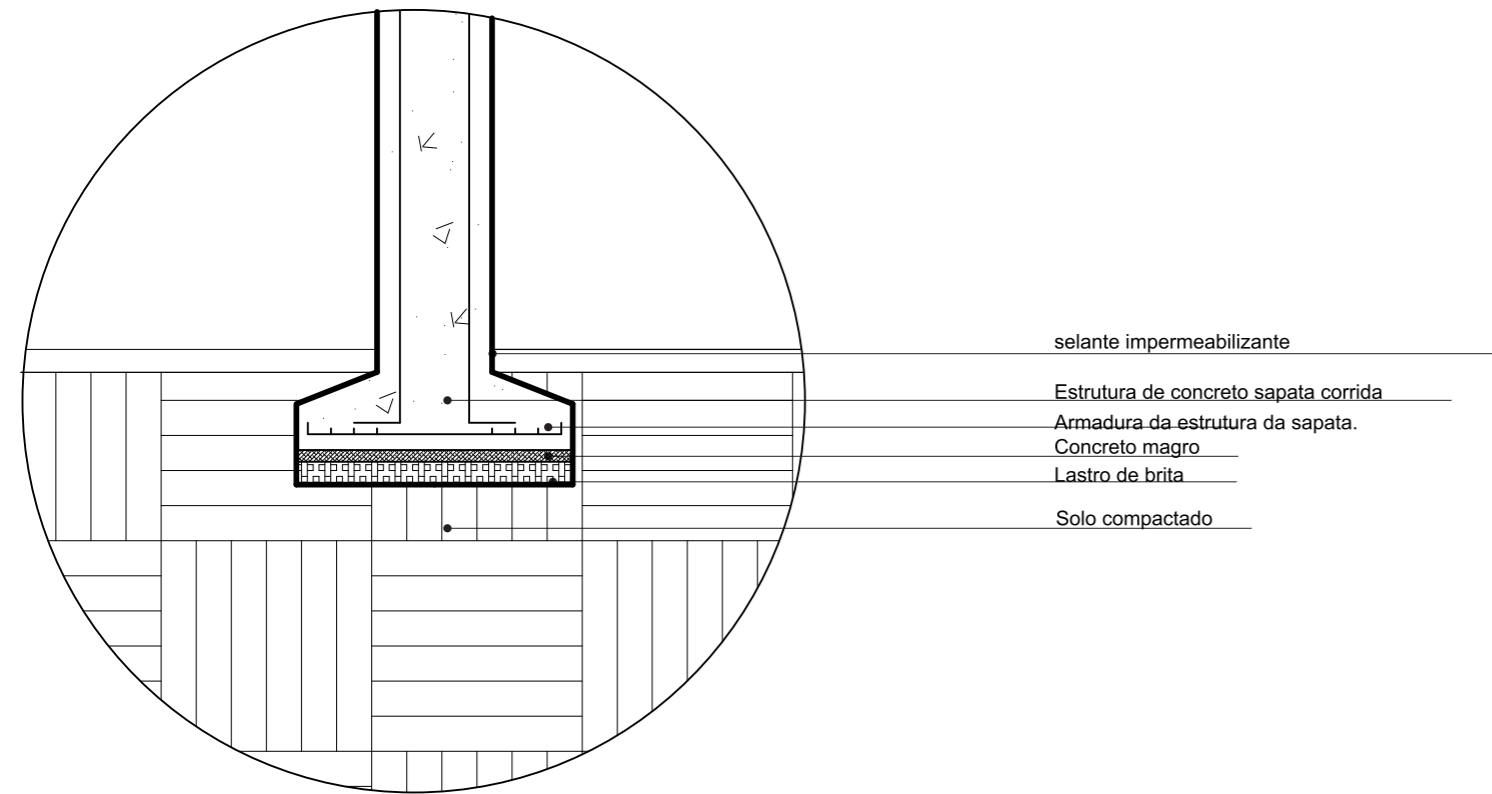

Esquema de fixação do porobolt, introduzindo na estrutura de concreto.

## MÉTODO DE APLICAÇÃO

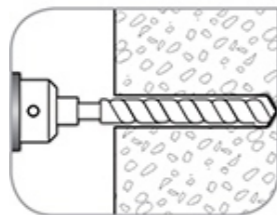

Faça o furo com diâmetro e profundidade indicados.

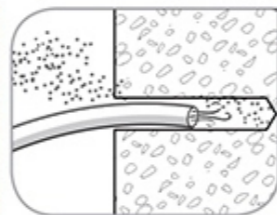

Limpe o furo.

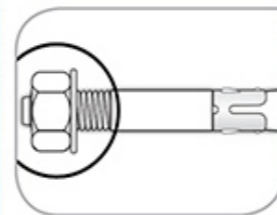

Coloque a porca e arruela na extremidade do chumbador.

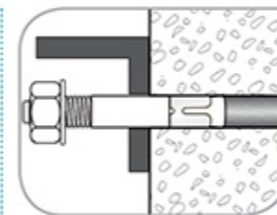

Posicione a peça a fixar e introduza o chumbador.

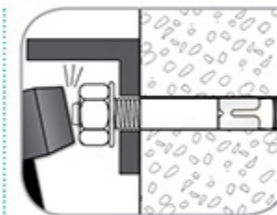

Com auxílio de marreta introduza o chumbador no furo.

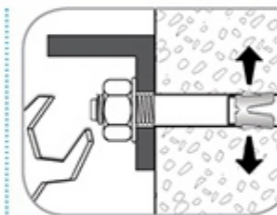

Aperte a porca provocando a expansão concluindo a fixação.









# REFERENCIAS:

Abreu, Maurício A. de **A Evolução Urbana da Cidade do Rio de Janeiro**, (IPLANRIO de 1997-2ª Edição-Rio de Janeiro).

AZEVEDO, Estezilda Berenstein de (org.). **Requalificação urbana e cultura da cidade**. Salvador: Faculdade de Arquitetura da UFBA, 2003. Tradução de Matteo Viola. 228p.

BARBOSA, Eunice. **Evolução do uso residencial na área central do Município de São Paulo**. São Paulo: dissertação (mestrado), EPUSP, 2001.

BONDUKI, Nabil. **Do cortiço à habitação digna: uma questão de vontade política**. São Paulo, Revista Urbs, Associação Viva o Centro, ano II, no 11, mar, 1999.

FROTA, José Artur D'Alá. Re-arquiteturas. **ARQTEXTO 5**. UFRGS, P.110 141, 1º semestre de 2004.

GERGHI, Luciana Carla Pezzolante, **Sobreposições de arquiteturas como forma de intervir no espaço urbano consolidado**, 2012. 195 f. Dissertação (Mestrado em arquitetura e urbanismo) - Coordenação de programa de pós Graduação em arquitetura e urbanismo da universidade presviteriana Mackenzie. São Paulo.

LEVINSON, M. **the Box: how the shipping container Made the world smaller and the World Economy Bigger**. 9. ed. New Jersey: Princeton University Press , 2006. 376 p.

SLAWIK, Han. **Container Atlas: A Practical Guide to Container Architecture**. Gestalten Verlag; Edição: 01 ,01, abril de 2010.

VARGAS, Heliana Comim, CASTILHO; Ana Luisa Howard de. **Intervenções em centros urbanos: objetivos e resultados**. Barueri, SP: Manoele, 2006.

<http://www.anapolis.go.gov.br/portal/secretarias/desenvolvimento-social/pagina/minha-casa-minha-vida/>

<http://diamantesdaconstrucao.blogspot.com.br/2013/09/como-abrir-e-vao-para-montar-uma-escada.html>

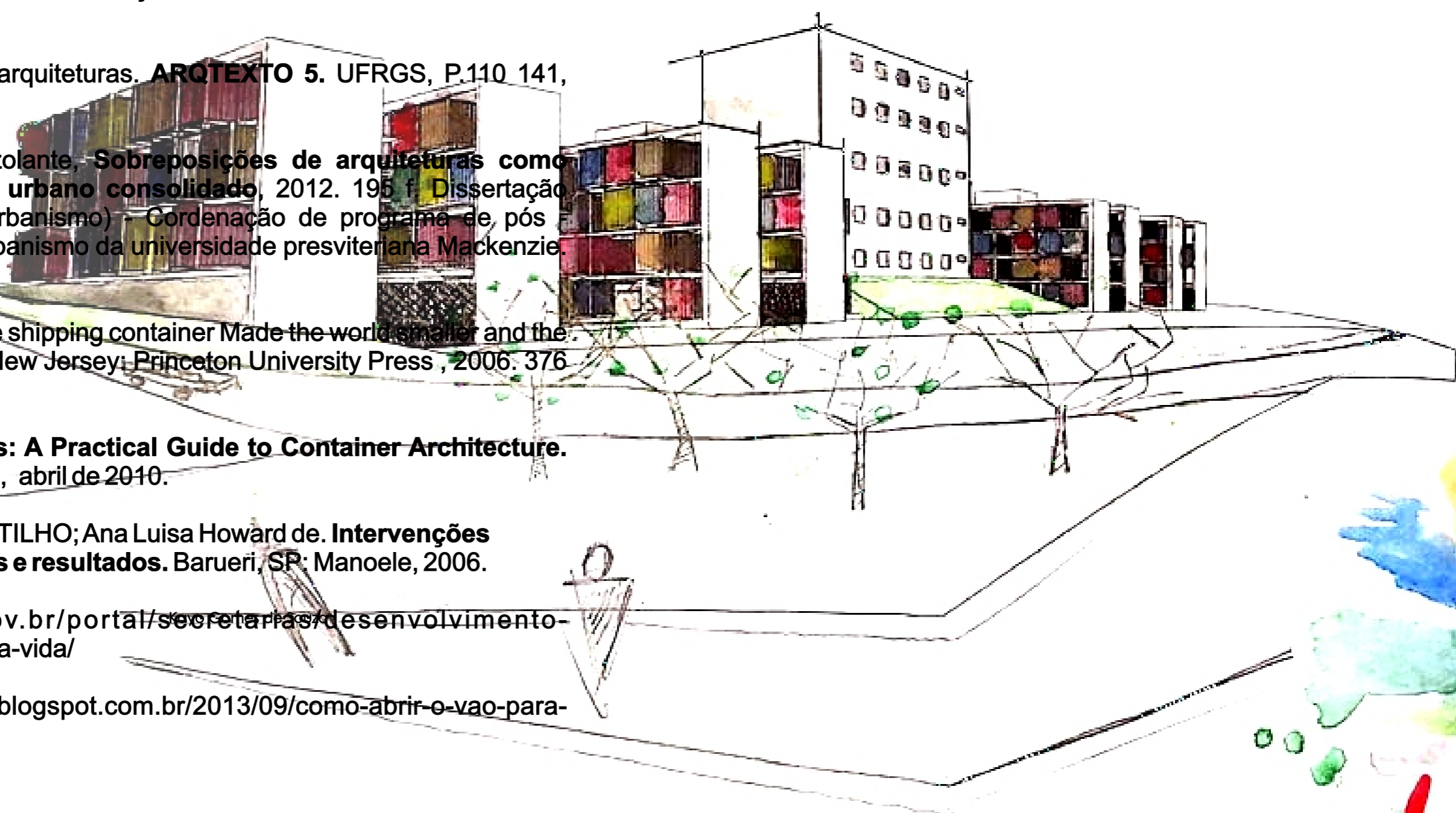

Obrigado!