

PASSEIO CULTURAL:

Intervenção Urbana e
Espaço de Lazer e Cultura
em Alexânia- Go



Centro Universitário de Anápolis
Faculdade de Arquitetura e Urbanismo
Acadêmico: Anderson de Lima Mota
Orientadora: Ana Amélia de Paula Moura



Necessidades Humanas: Lazer, Cultura e Interação



NECESSIDADES HUMANAS: Lazer, Cultura e Interação



CRONOLOGIA:

Modificação do Espaço Urbano no sec.XX e XXI



SEC.
XX



SEC.
XXI

O EIXO BRASÍLIA GOIÂNIA : Relação Município Eixo.



O MUNICÍPIO: Áreas de 'LAZER' Urbano



O MUNICÍPIO: Áreas de 'LAZER' Urbano



O MUNICÍPIO: O Centro; Gabarito.

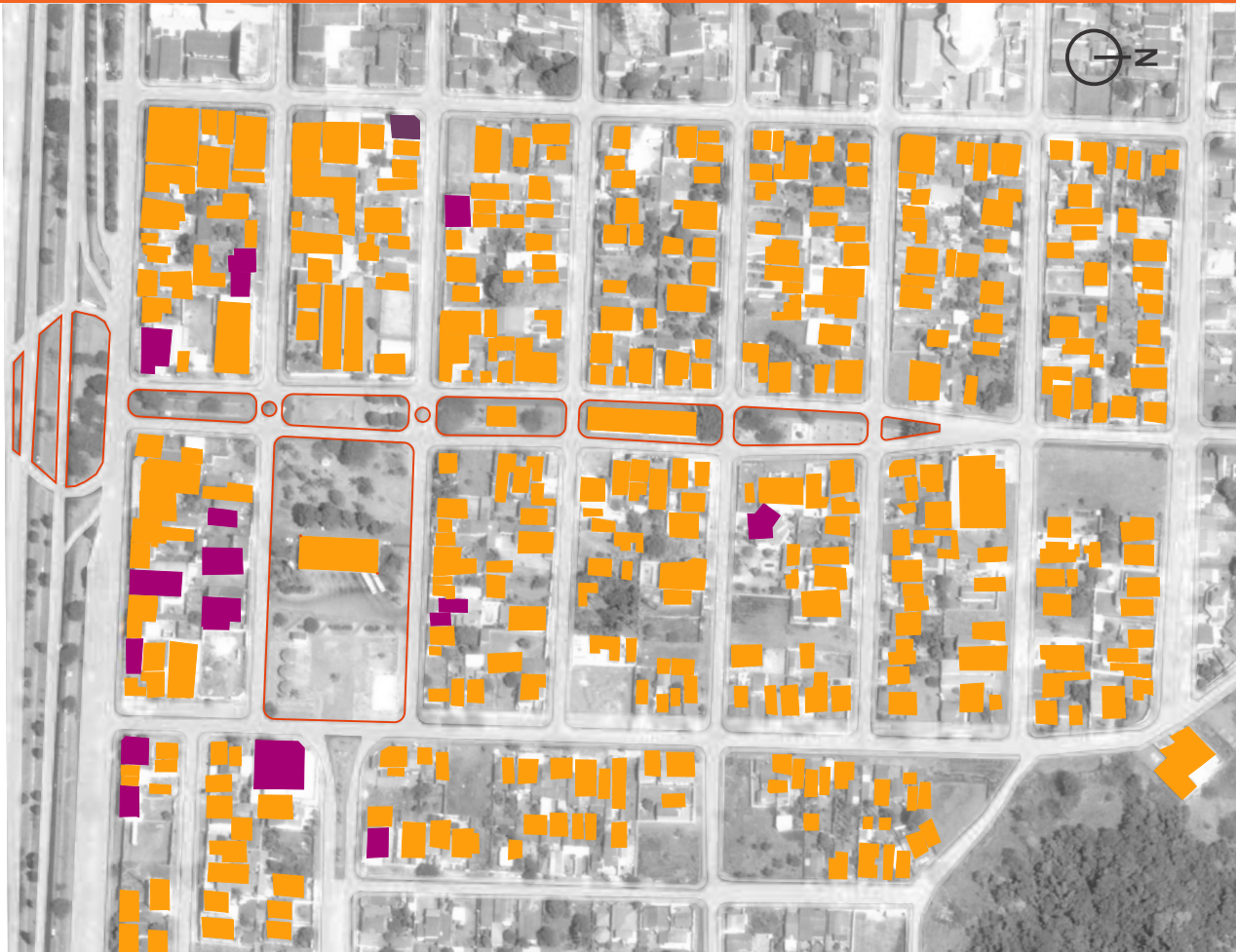

- Área de Ação
- Edifícios térreos
- 2 pavimentos
- 4 pavimentos

O MUNICÍPIO: A Decadência do Centro.



- Residencial
- Misto
- Comercial
- Serviço
- Institucional
- Educacional
- Sem Uso

O MUNICÍPIO: A Decadência do Centro.



O MUNICÍPIO: Diretrizes Urbanas.

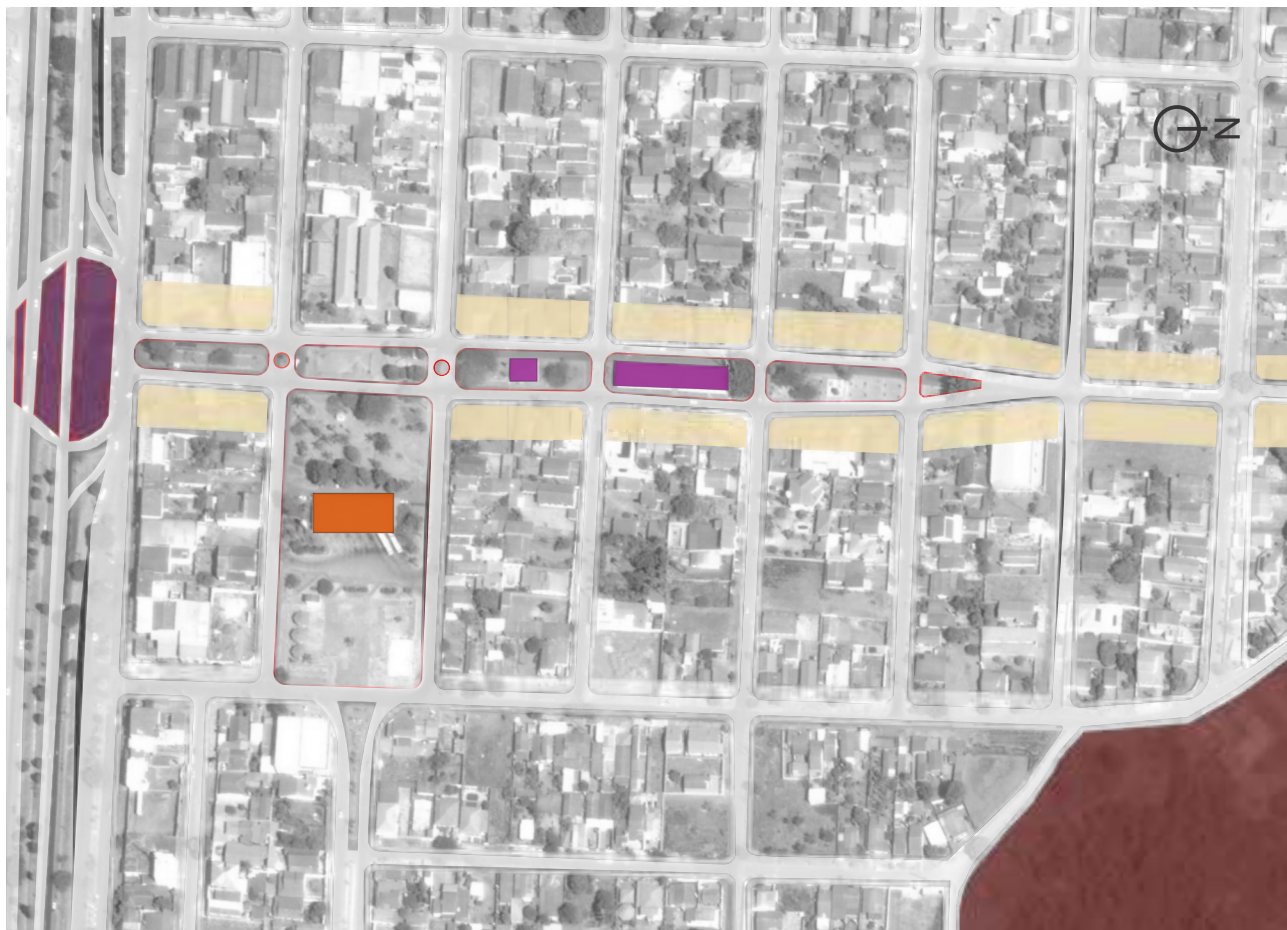

- Área de Ação
- Área c/ Potencial
Uso Comercial
- Rotatória da BR
- Rodoviária
- Sec. municipais
- Área do Parque

O EDIFÍCIO: Programa.

2 Salas de pintura- 94 m²
3 Salas de trabalhos manuais- 141 m²
1 Sala de informática- 74 m²
2 Salas de dança 50 m²
Secretaria- 68 m²
Biblioteca- 56 m²
Recepção- 88 m²
Dlm- 10 m²
Almoxarifado- 10 m²
Área de convivência- 138 m²
Banheiros- 66 m²

Equip. Cultural
49%
921 m²

**SEC. Educação
e cultura**
25%
482 m²

4 Salas de trabalho - 74 m² total
Estação de trabalho coletivo
25m²
Sala de reunião- 28m²
Almoxarifado/ Dml- 24 m²
Recepção- 71 m²
Copa- 31m²
Área de Convivência - 63m²
Banheiros- 53 m²

Rodoviária
26%
526 m²

Bilheteria- 22m²
Dml- 10 m²
4 lojas 142m²
Administração- 48 m²
Banheiros- 93m²
Espaço de espera 150 m²

O EDIFÍCIO: Diagramas de Composição de Forma.

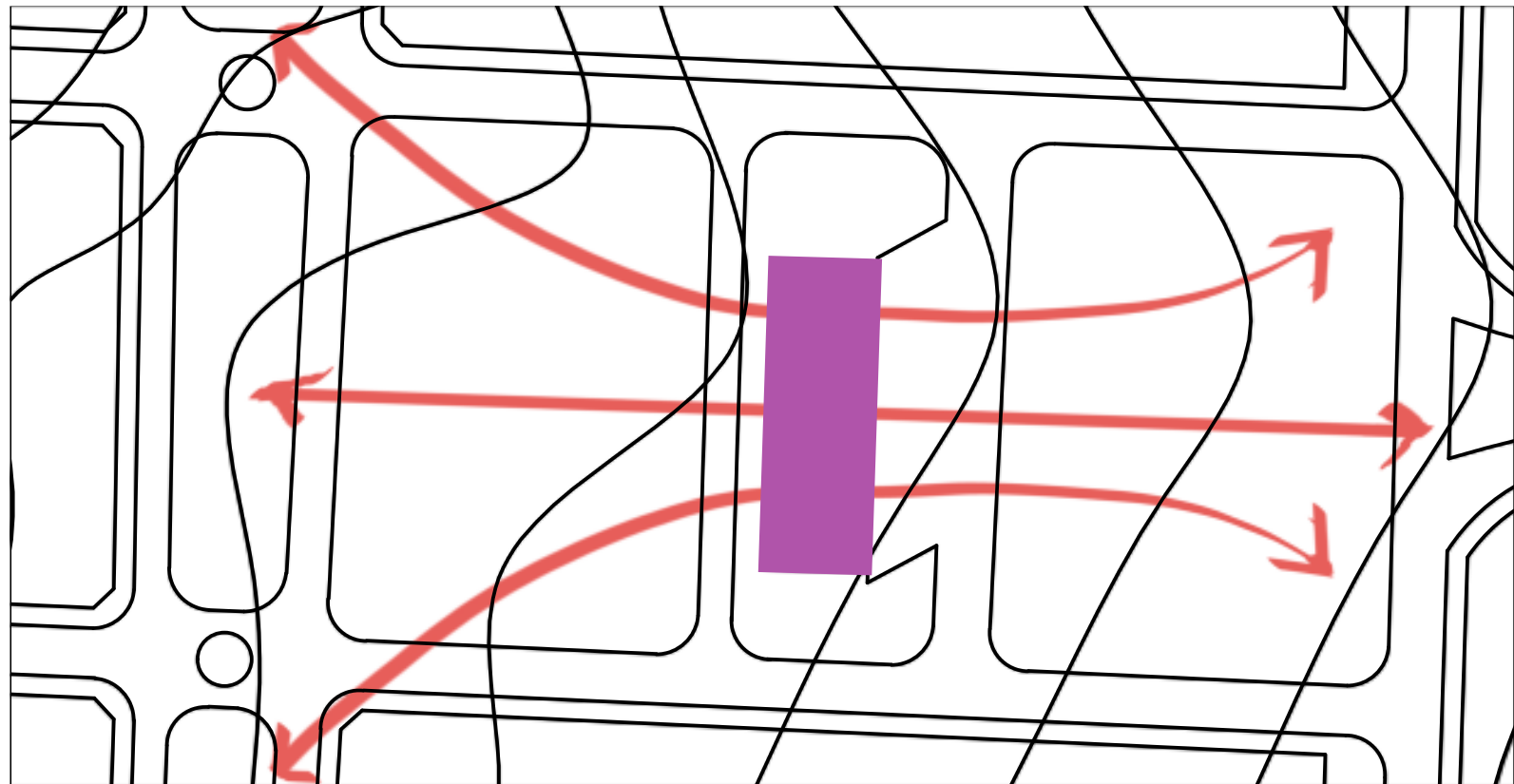

O EDIFÍCIO: Diagramas de Composição de Forma.

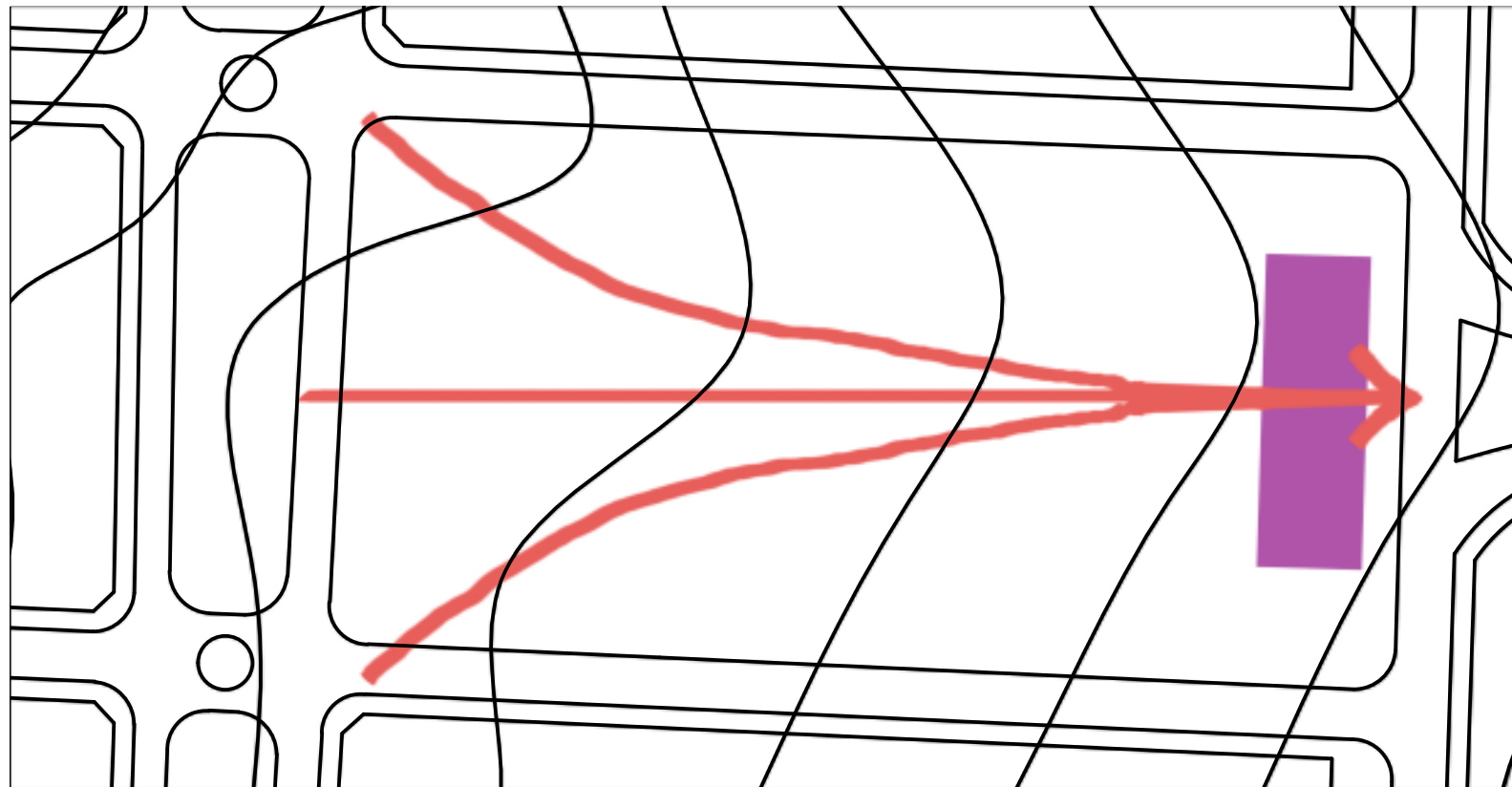

O EDIFÍCIO: Diagramas de Composição de Forma.

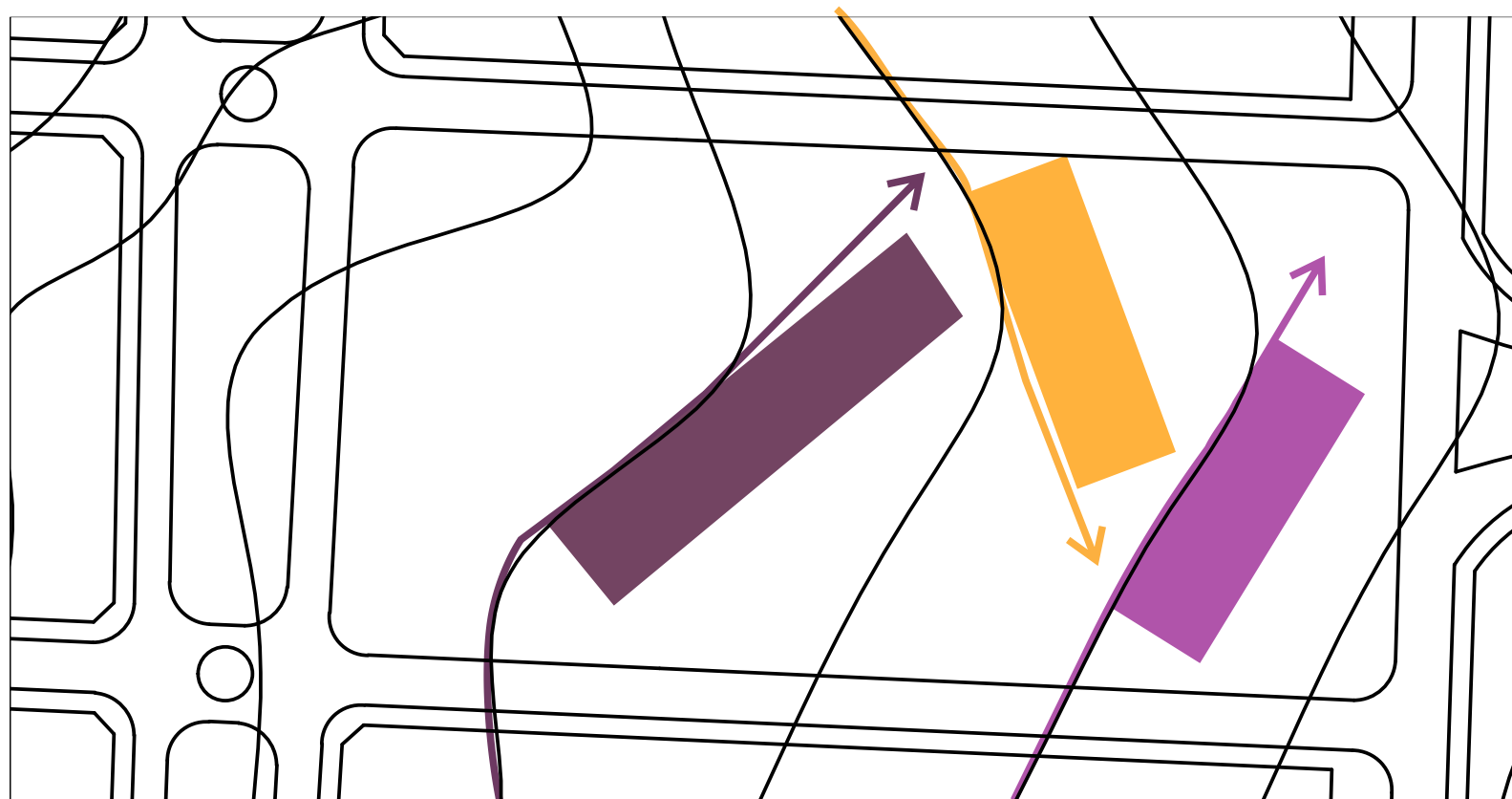

O EDIFÍCIO: Diagramas de Composição de Forma.

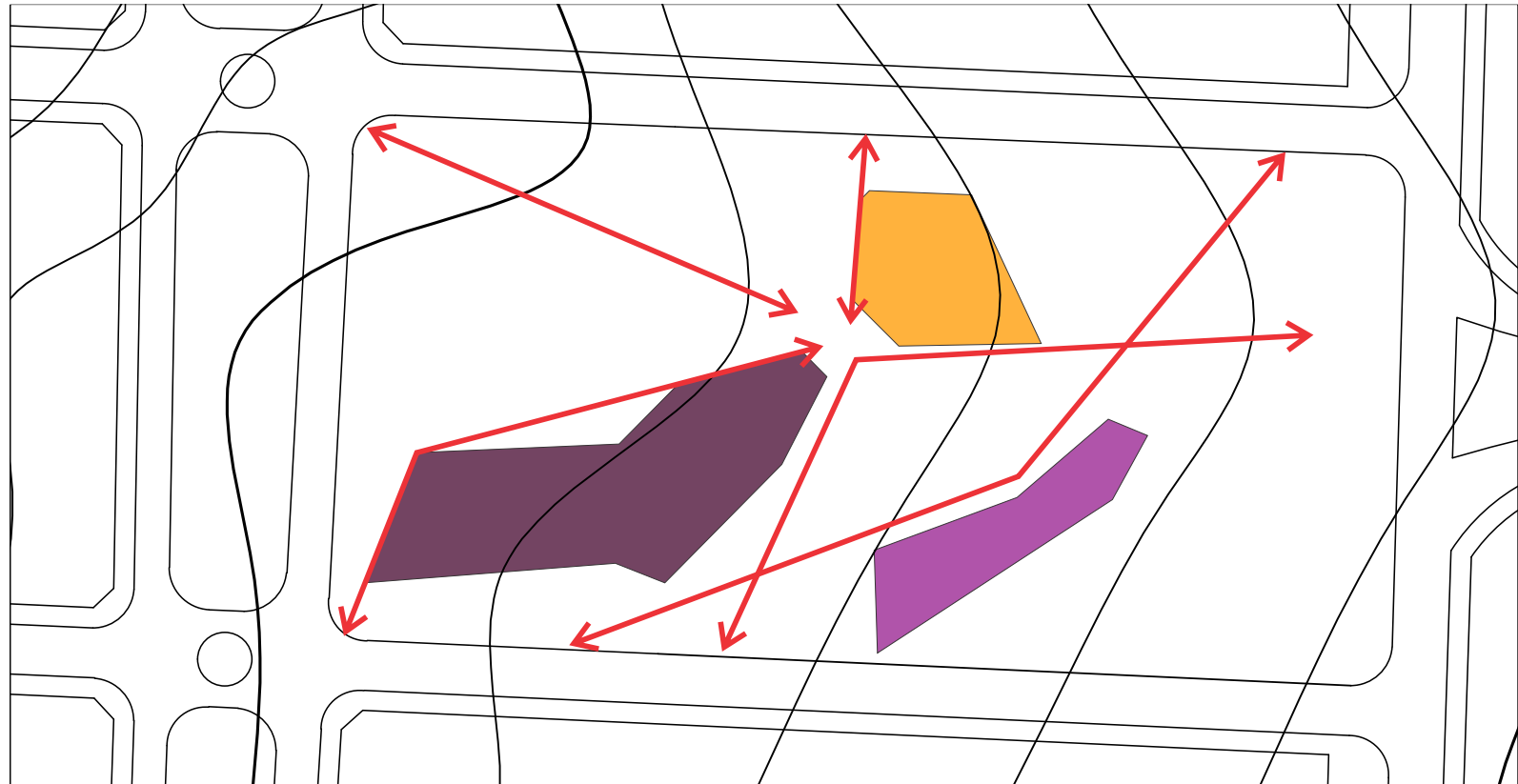

0 EDIFÍCIO: Diagramas de Composição de Forma.

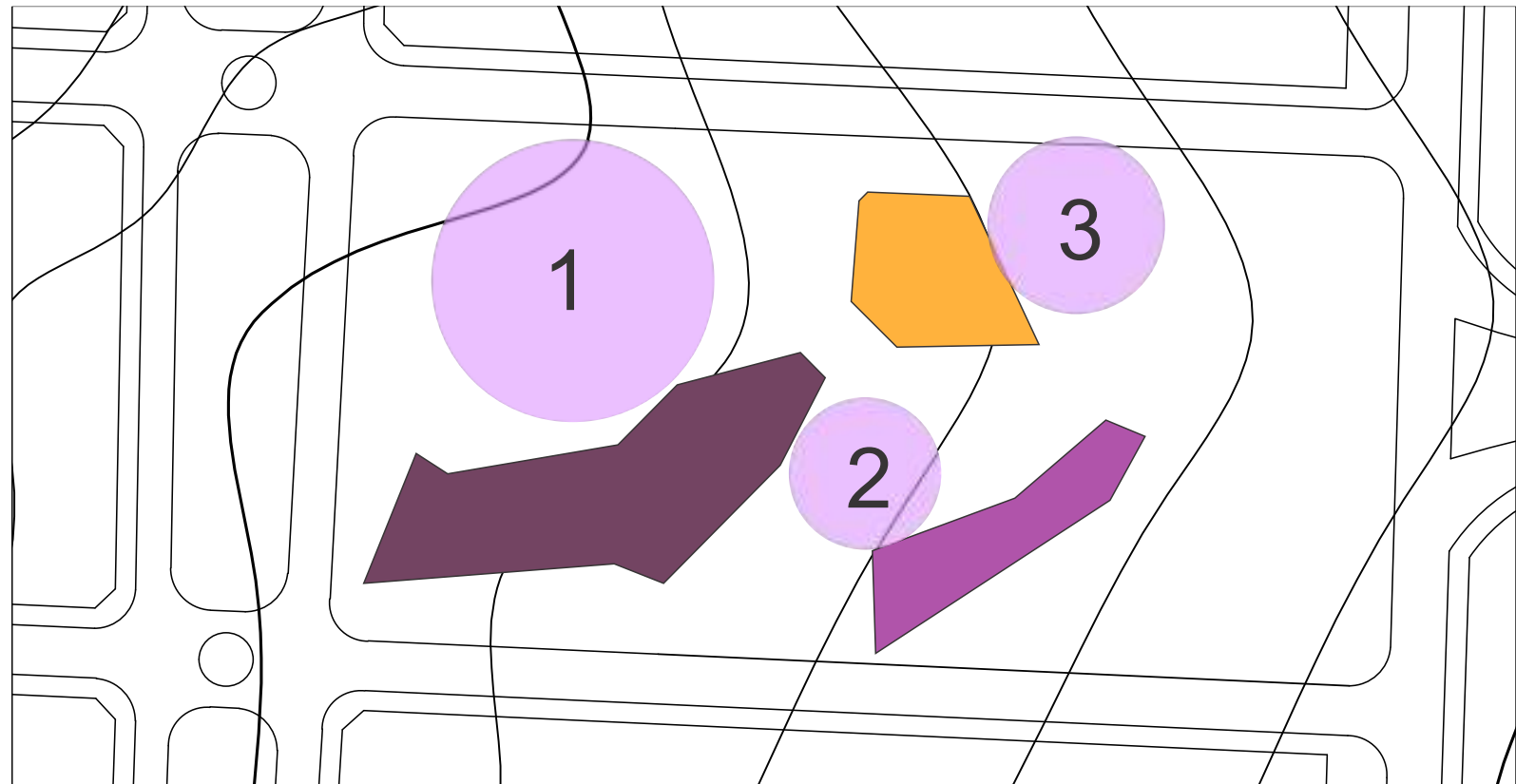

O EDIFÍCIO: Diagramas de Composição de Forma.

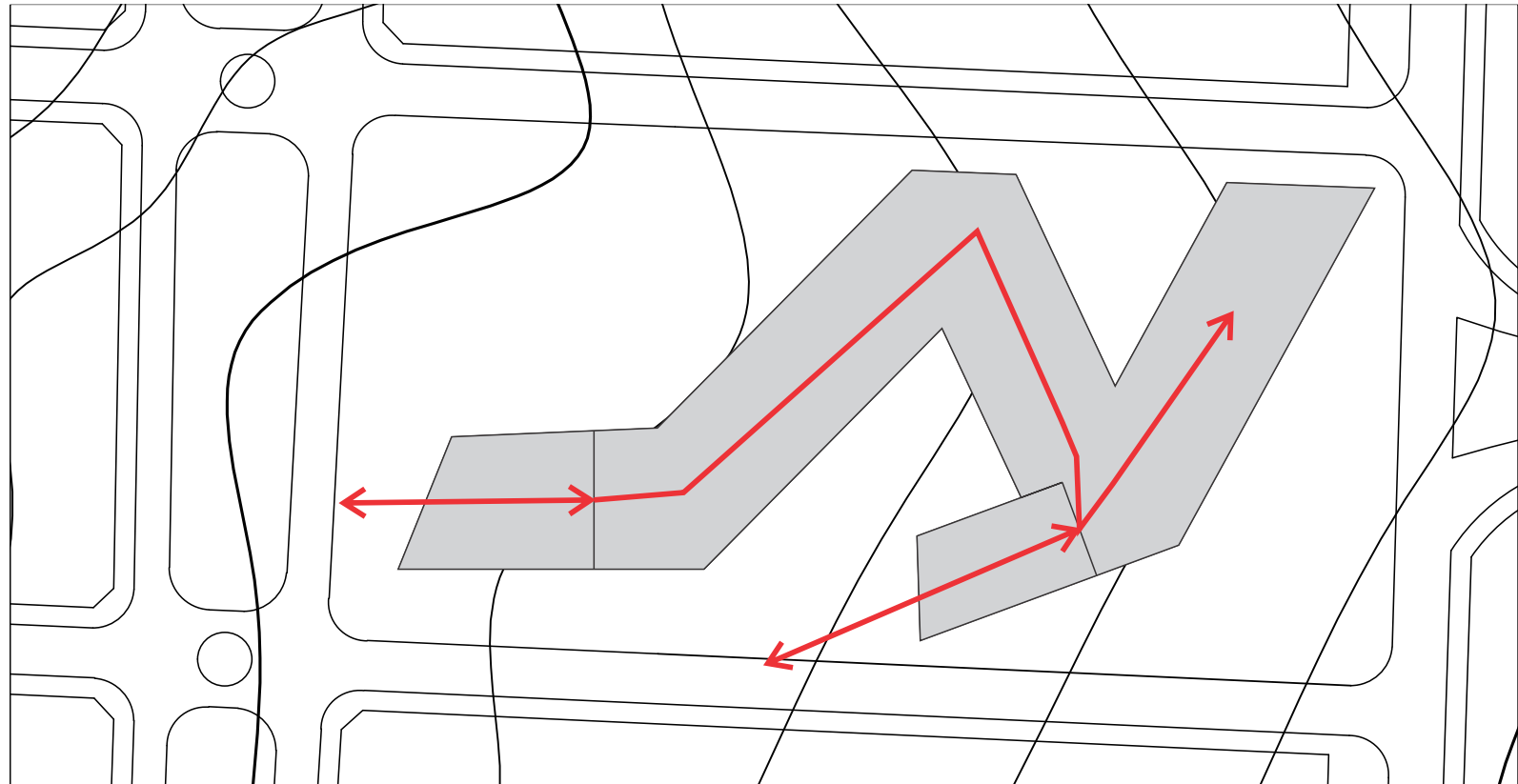

O EDIFÍCIO: Diagramas de Composição de Forma.

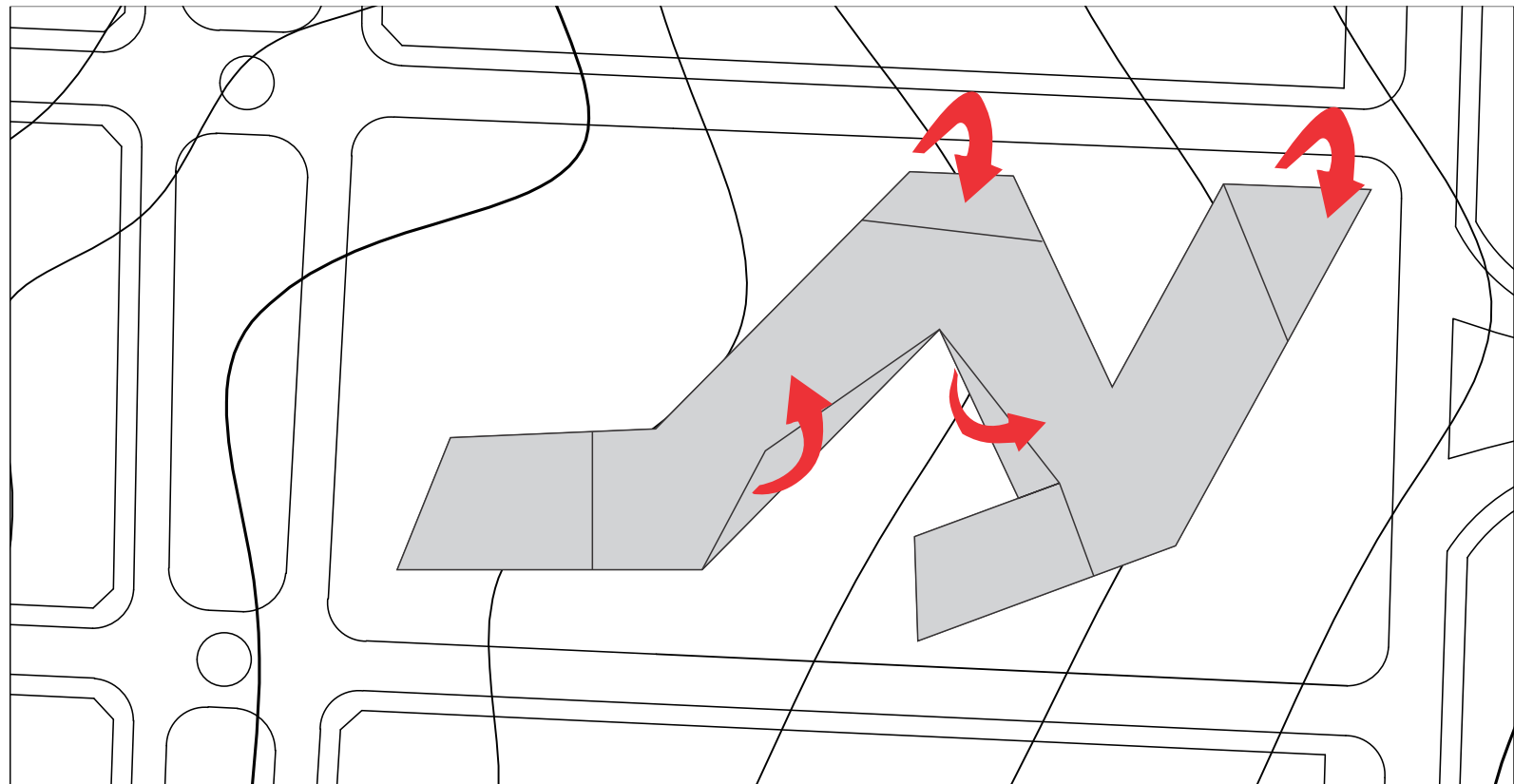

O EDIFÍCIO: Diagramas de Composição de Forma.

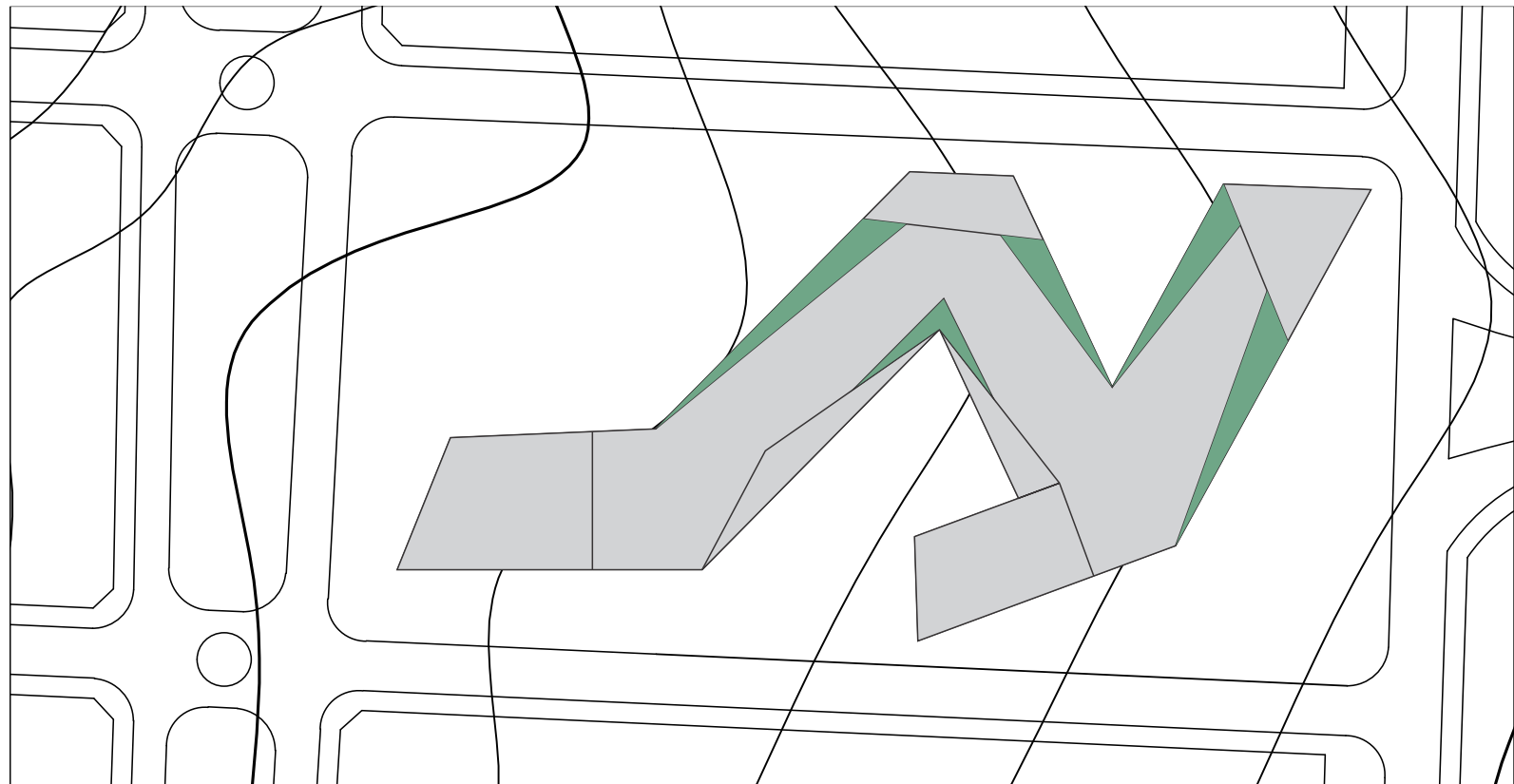

O EDIFÍCIO: Diagramas de Composição de Forma.

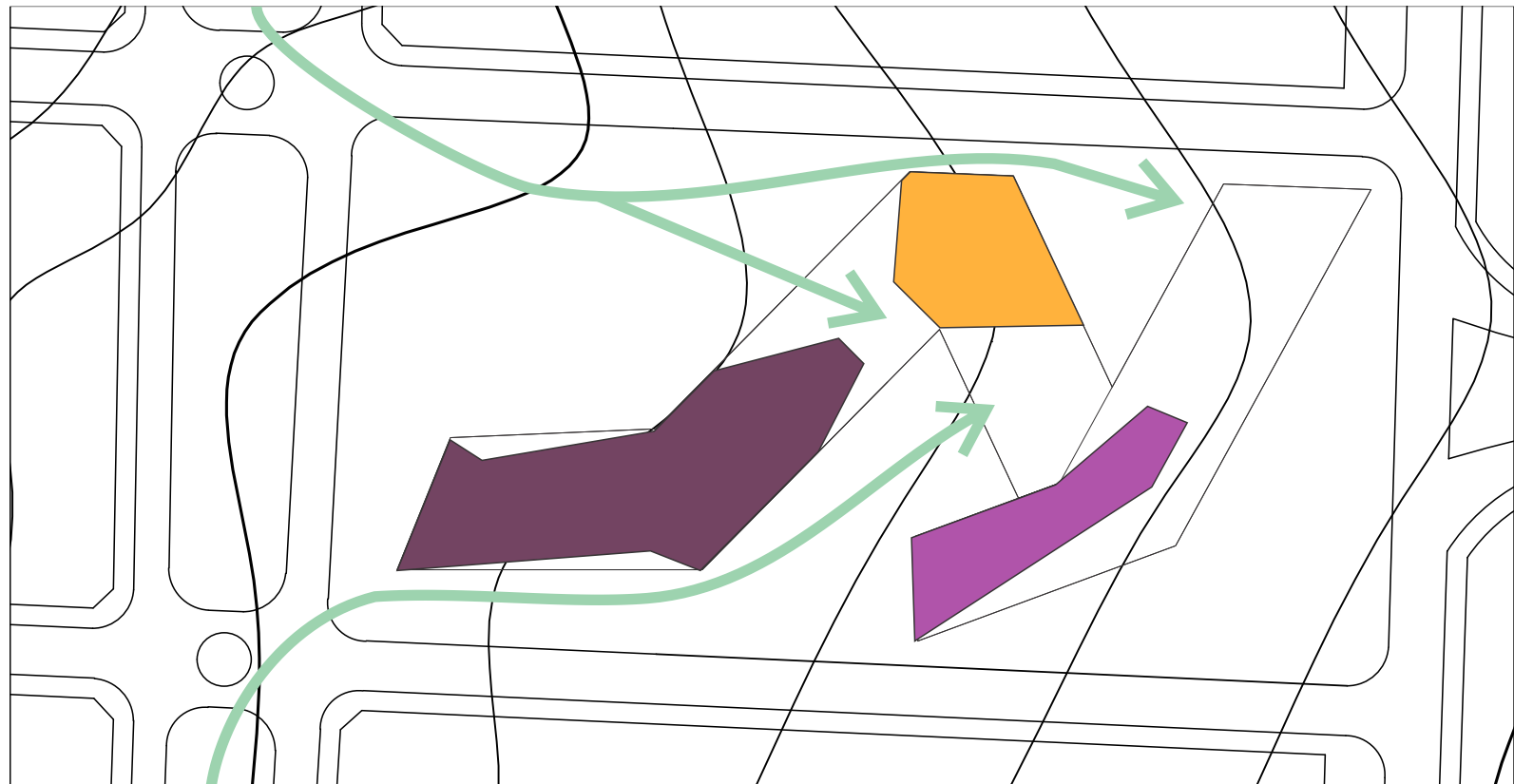



O EDIFÍCIO: Diagramas de Composição de Forma.

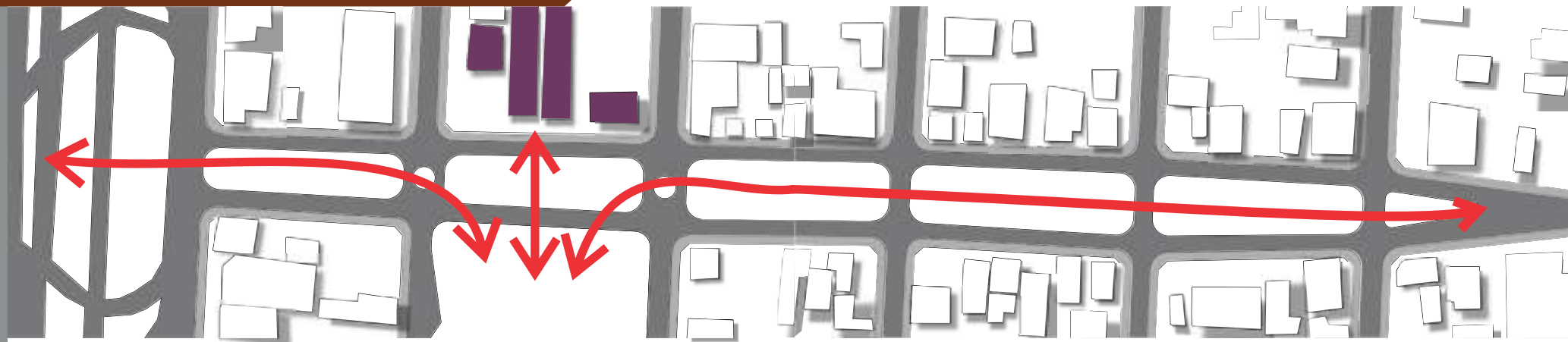



O EDIFÍCIO: Diagramas de Conforto.

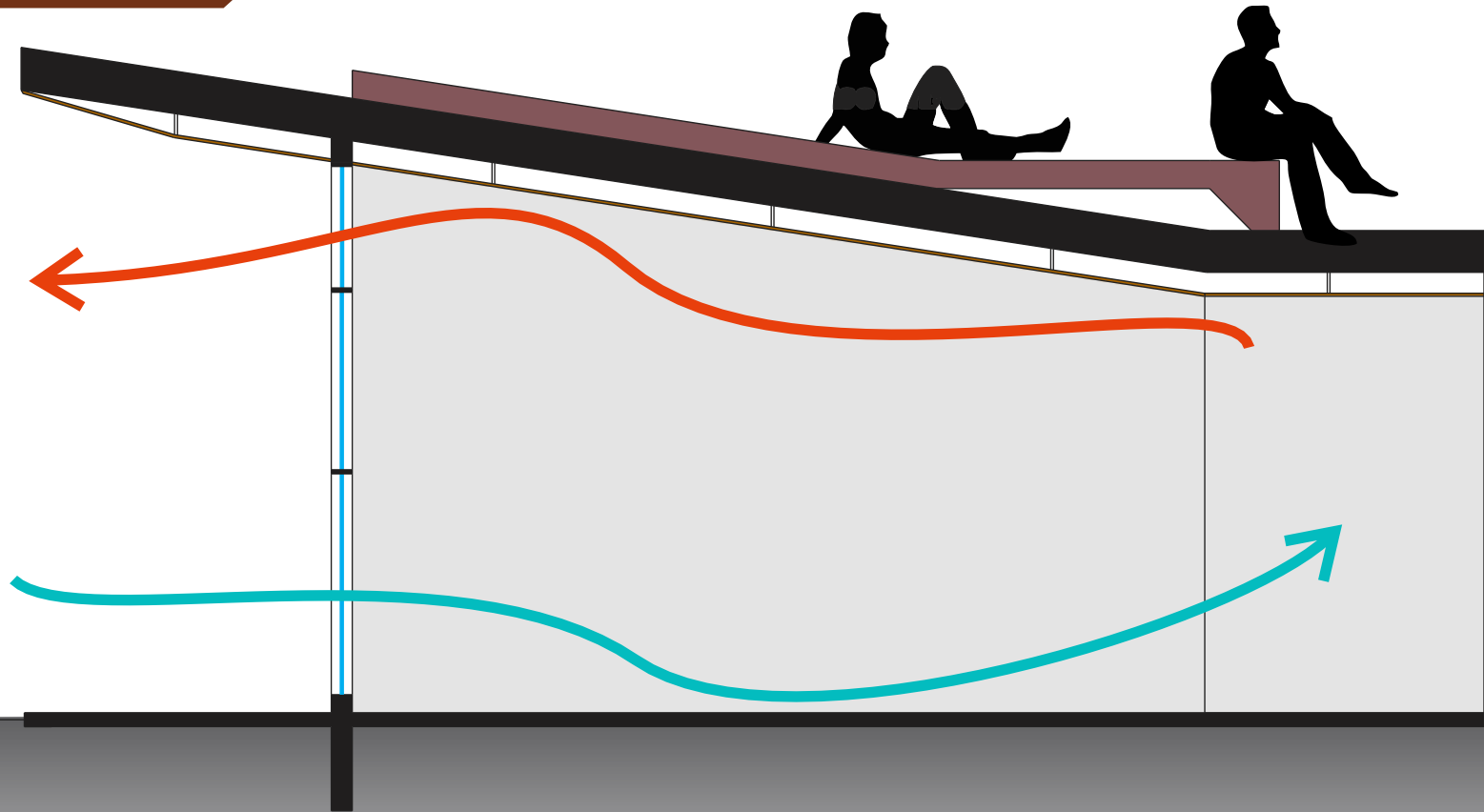

0 EDIFÍCIO: Diagramas de Conforto.

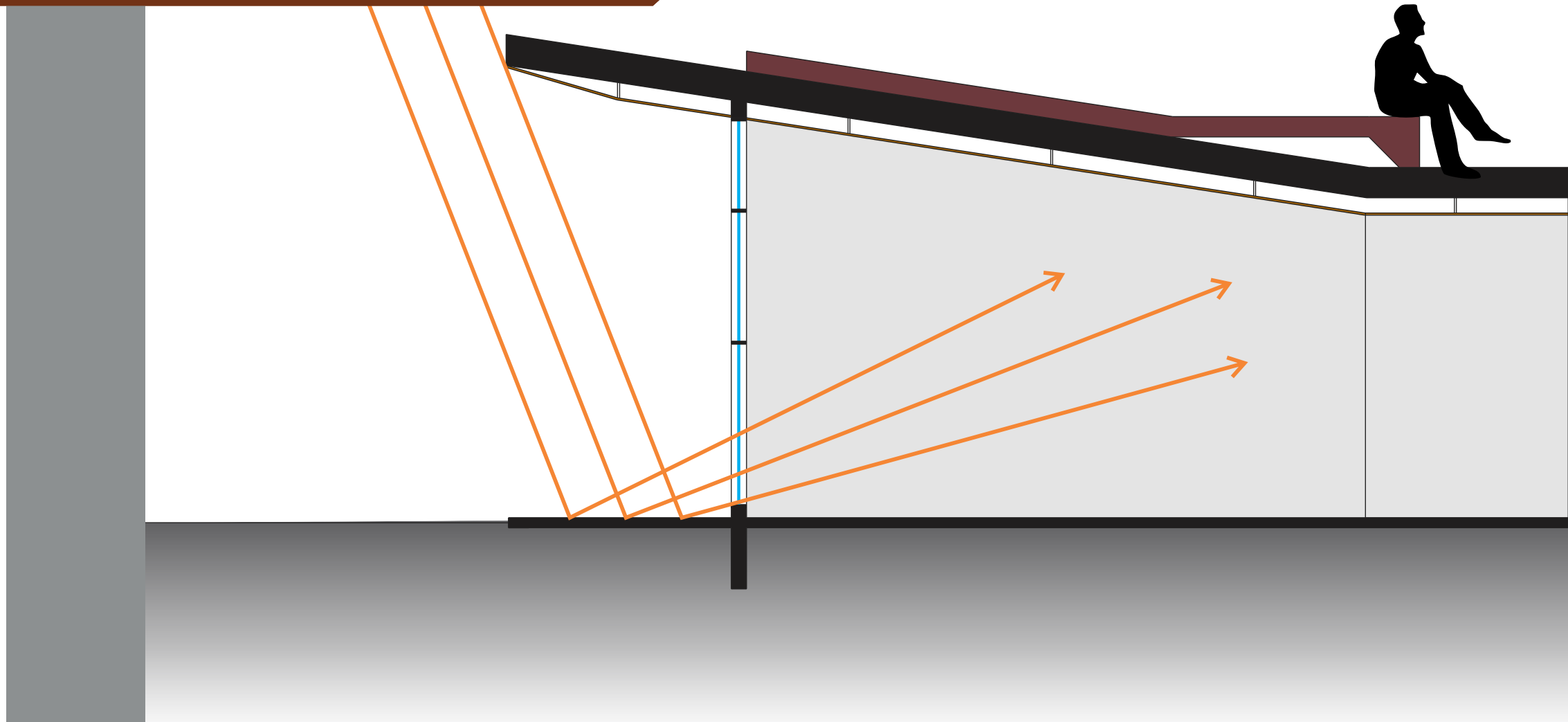





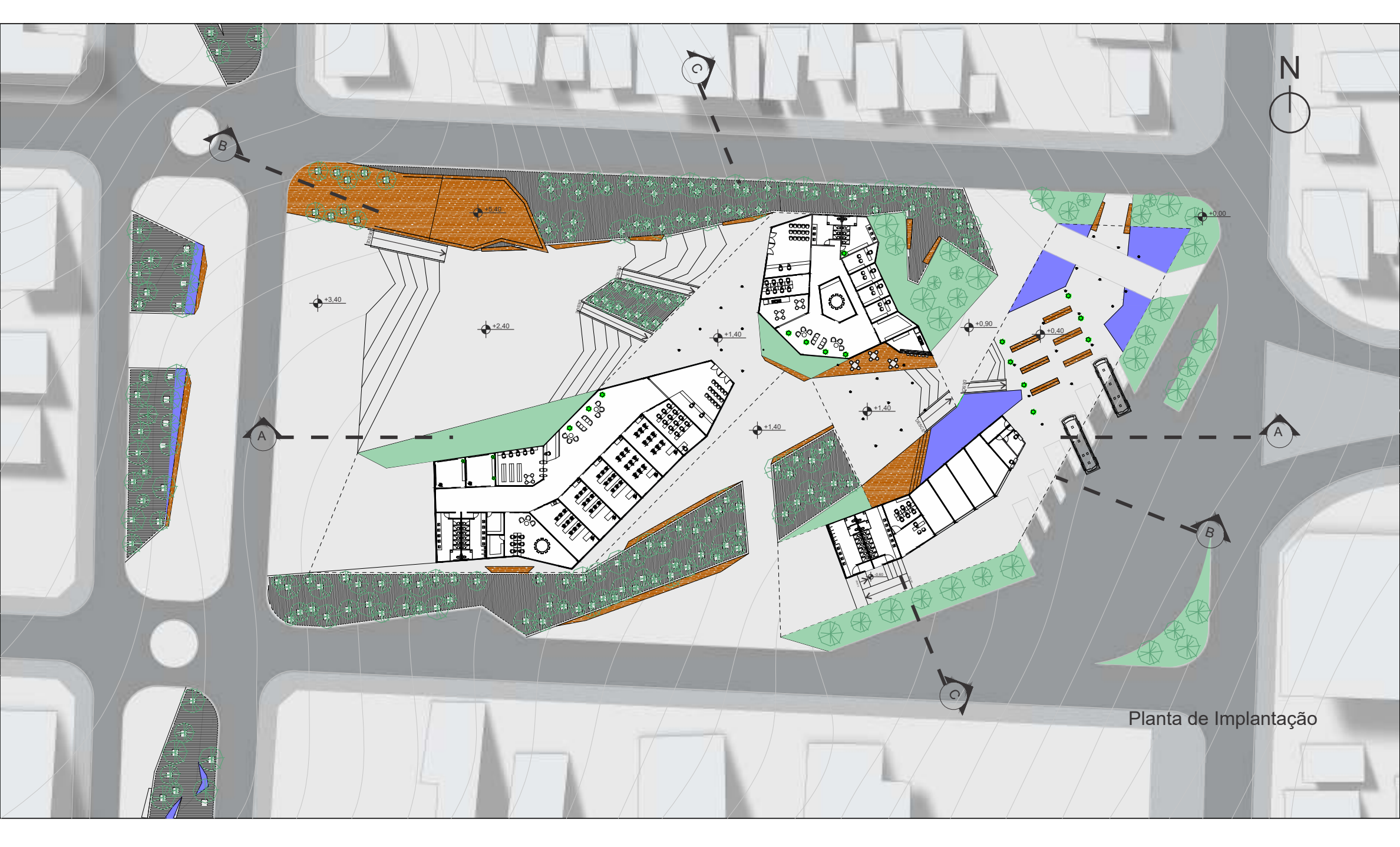

Planta de Implantação

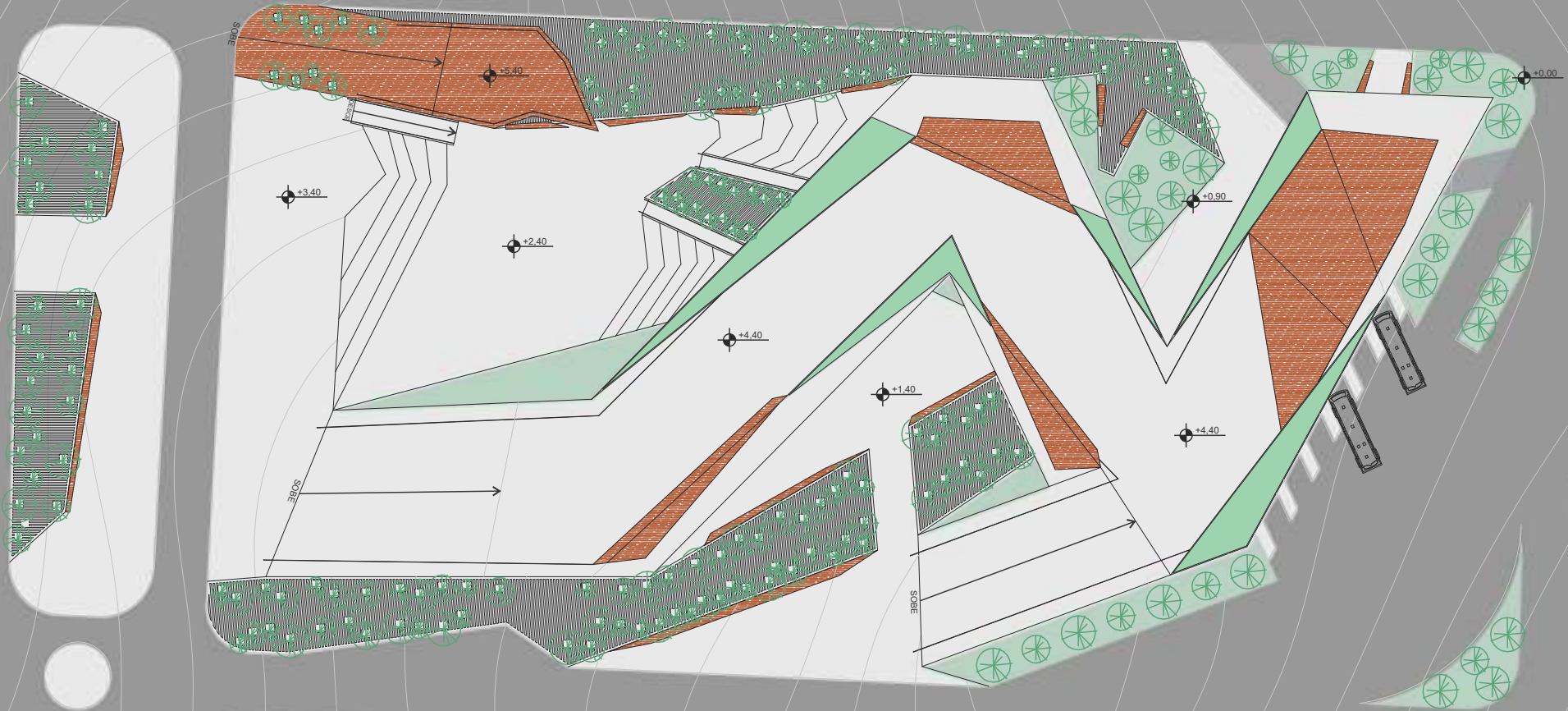

Planta da Cobertura

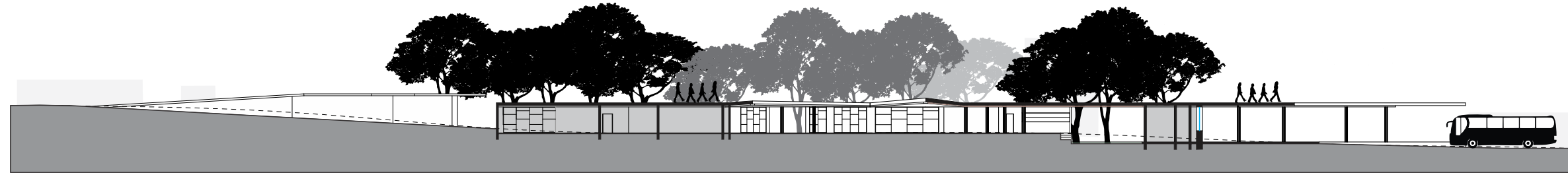

Corte AA

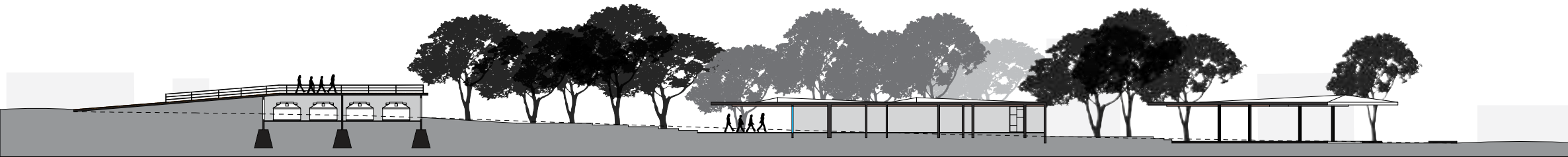

Corte BB

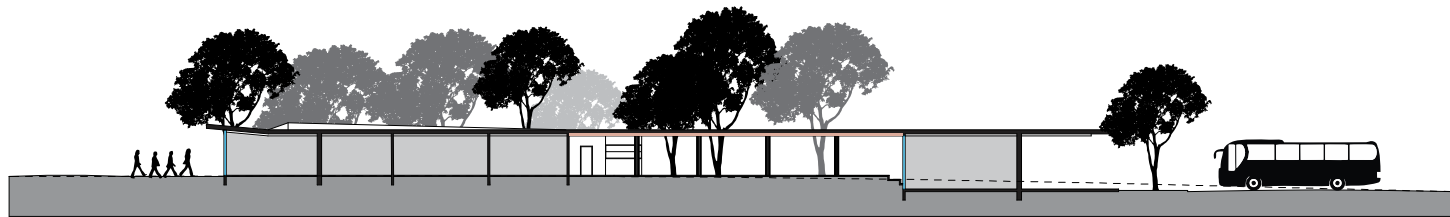

Corte CC



Fachada Oeste

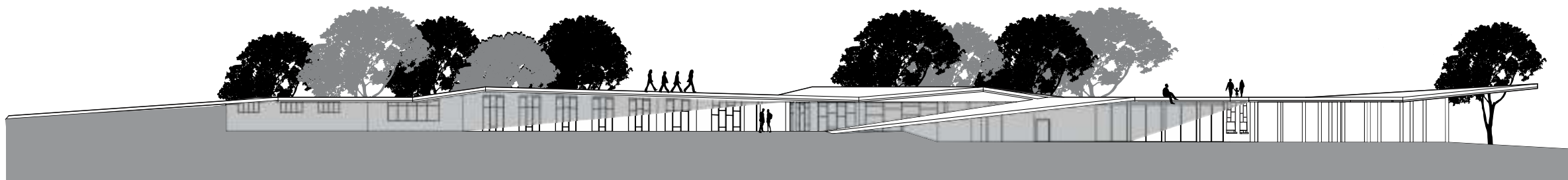

Fachada Sul



Fachada Norte

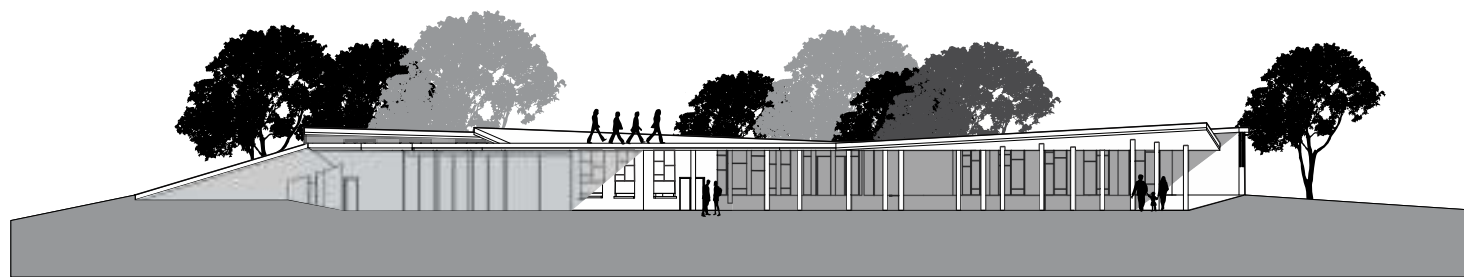

TECNOLOGIAS: Detalhe Canteiro laje.

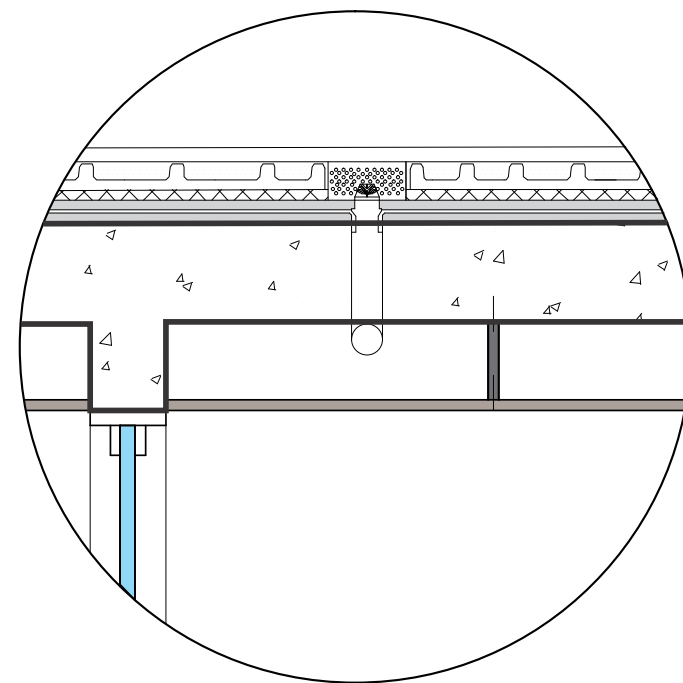
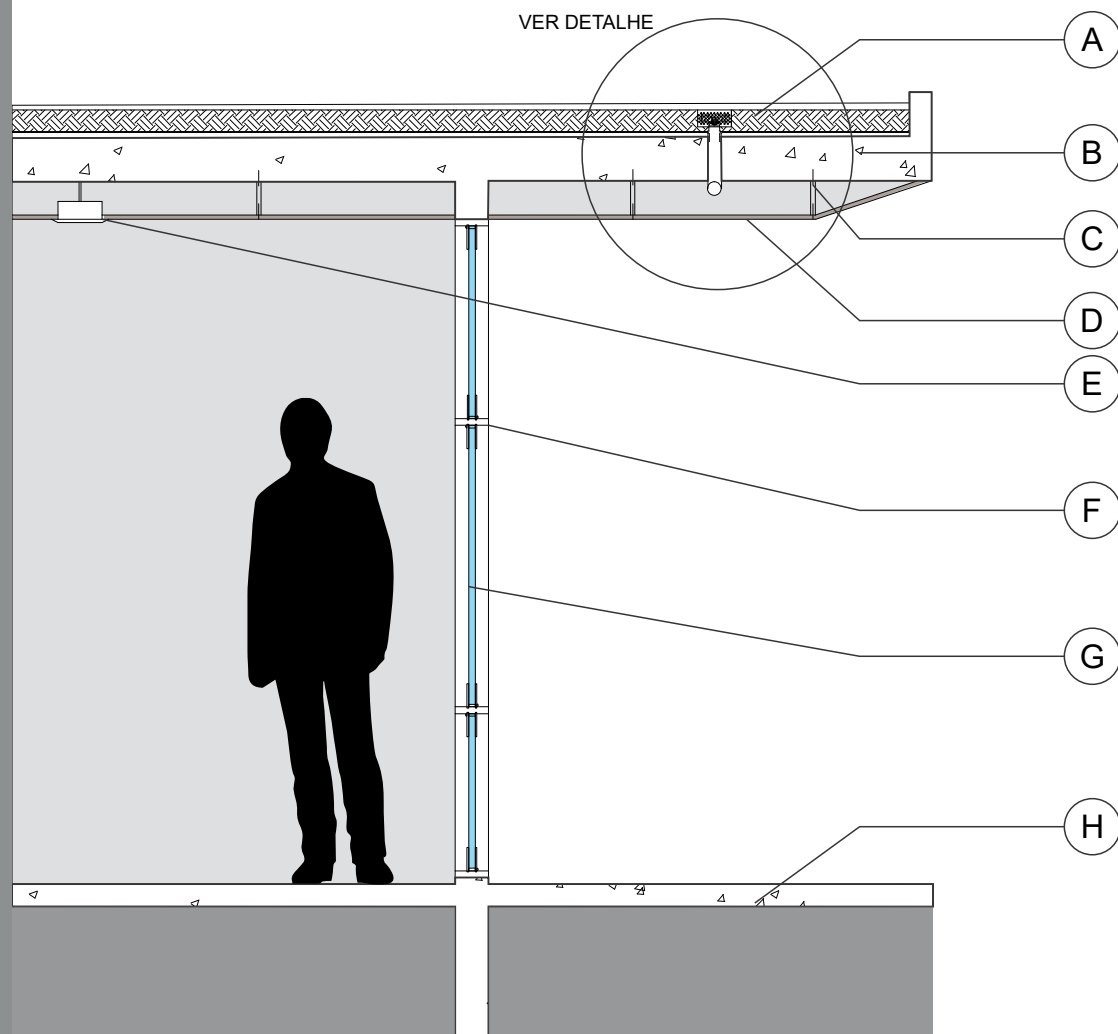

TECNOLOGIAS: Detalhe Bancos e Vedações.

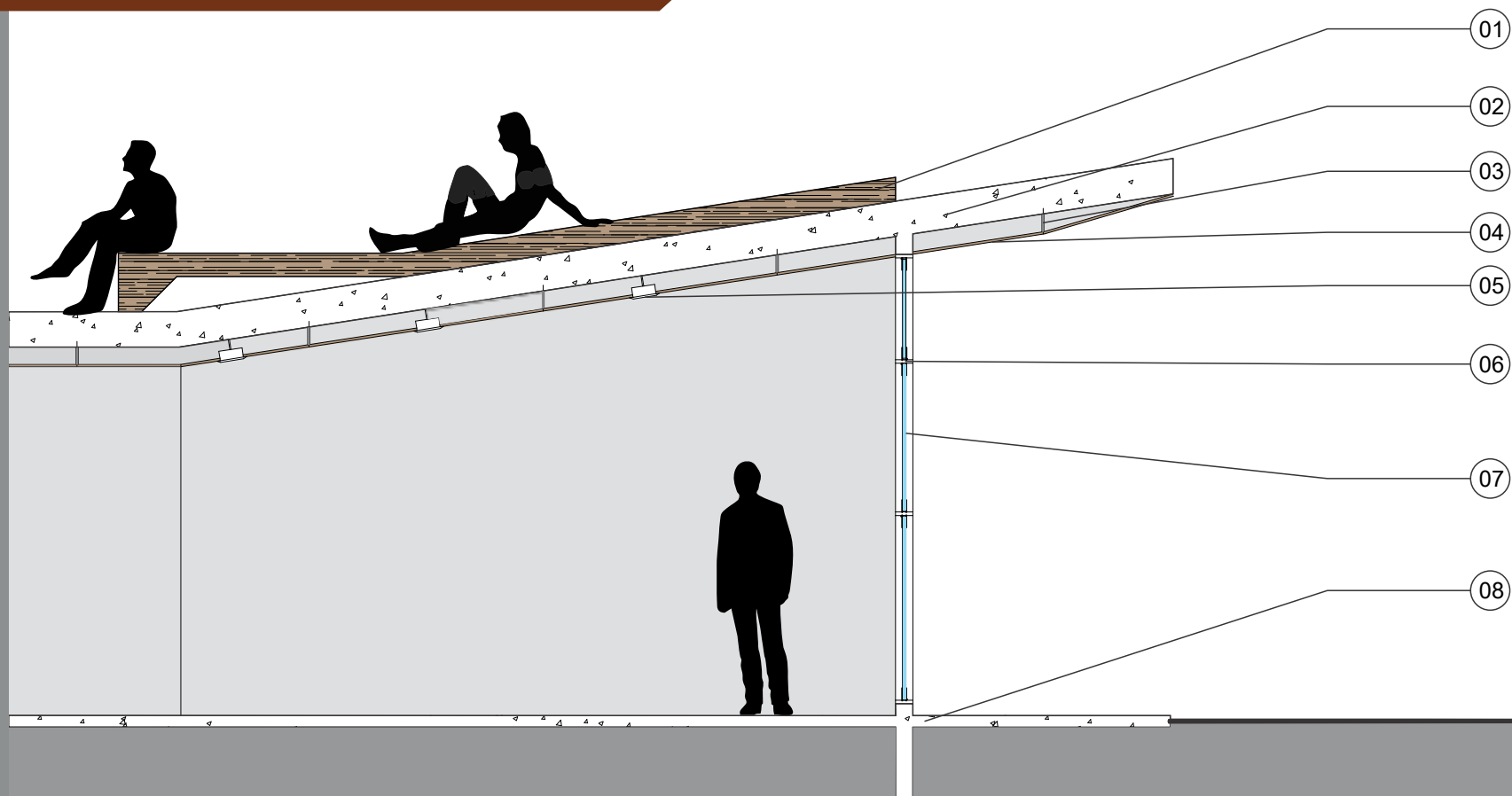

TECNOLOGIAS: Detalhe Mirante Reservatório

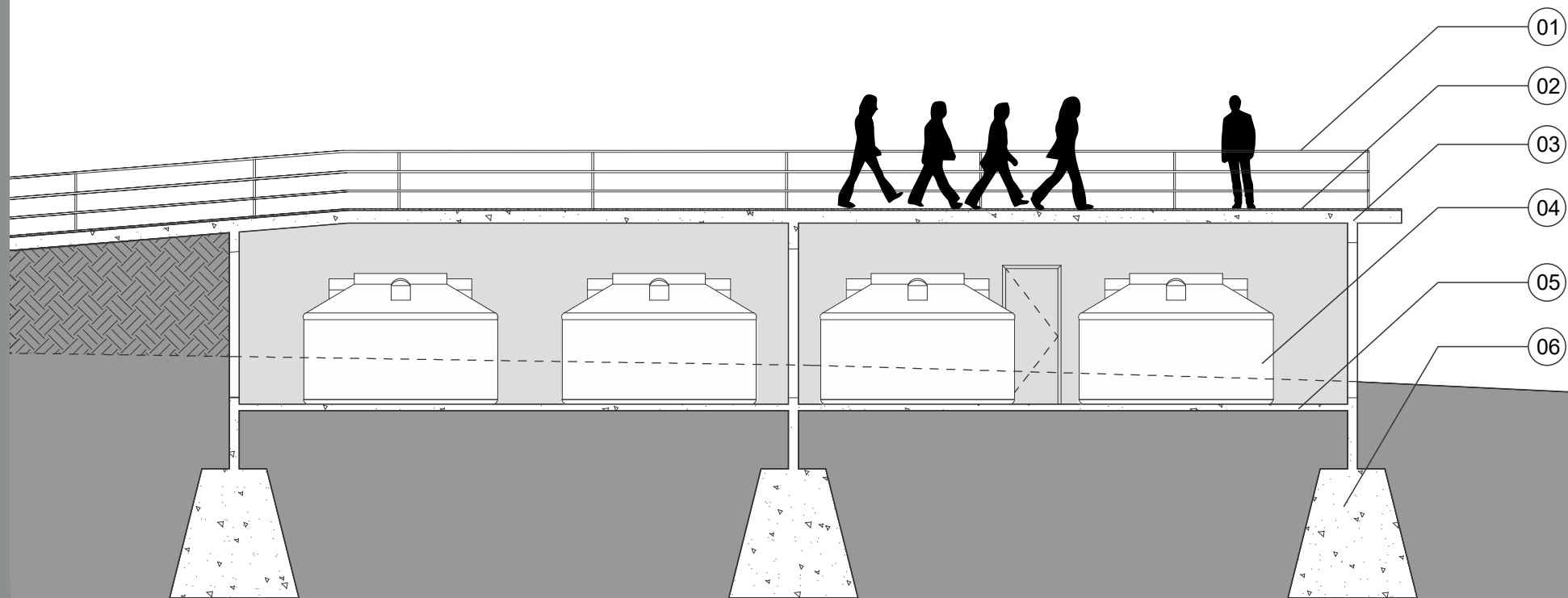









BIBLIOGRAFIA:

Referencias Bibliográficas

- MILANESI, Luís. A Casa da Invenção: Biblioteca, Centro Cultural. 4ª ed. revisada e ampliada. São Paulo: Ateliê Editorial, 2003.
- JACOBS, Jane. Vida e Morte de Grandes Cidades. 3ª ed. Tradução Carlos S. Mendes Rosa. São Paulo: Livraria Martins Fontes Editora Ltda, 2011.
- RAMOS, Luciene Borges. Centro Cultural: Território privilegiado da ação cultural e informacional na sociedade contemporânea. Disponível em: < <http://www.cult.ufba.br/enecult2007/LucieneBorgesRamos.pdf>>. Acessado em 25 de março de 2017.
- COELHO, Teixeira. Dicionário Crítico de Política Cultural. 2ª ed. Revisada e ampliada. São Paulo: Editora Iluminuras, 1997
- VARGAS, H. C. & CASTILHO, A.L.H. Intervenções em Centros Urbanos. 3ª ed. São Paulo: Editora Manole 2015.
- LEFEBVRE, Henri. A Revolução Urbana. 1ª ed. Belo Horizonte: Editora UFMG 1999.
- MATOS, Fátima Loureiro de. Espaços públicos e qualidade de vida nas cidades: O caso da cidade do Porto http://www.observatorium.ig.ufu.br/pdfs/2edicao/n4/Espacos_publicos.pdf> acessado em 25 de março de 2017
- BORJA, Jordi. Espacio público, condición de la ciudad democrática <http://www.cafedelasciudades.com.ar/politica_42_1.htm#1> Acessado em 25 de Março de 2017
- BORJA, Jordi, & MUXÍ, Zaida. El espacio público, ciudad y ciudadanía. ed 1ª, Barcelona: Editora Electa, 2003

